

**13th Summer School
on Economic History, Philosophy, and History of Economic Thought**

Cooperation and Conflicts: lessons from history and economic theory

Acqui Terme

Wednesday 1st September – Wednesday 8th September 2010

Money &

The disequilibrium dynamics of market economies

Rémi Stellan

University of Fribourg/Freiburg and University of Grenoble
PhD student with the financial support of the Distance University of Switzerland (FS-CH)



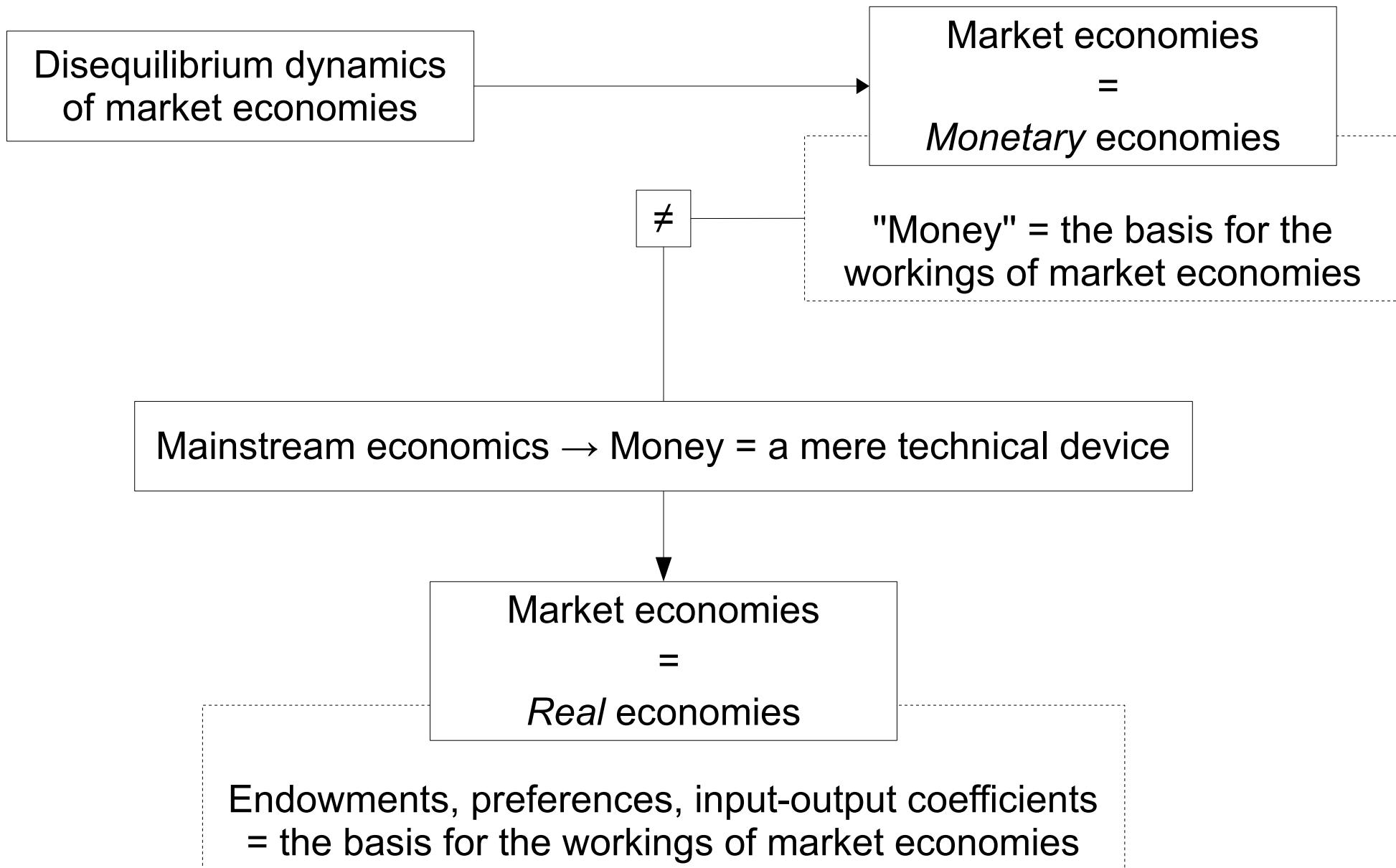

agents' decisions are *not* mutually compatible

Disequilibrium

e.g.

Unsold stocks of
consumption goods

Unemployment

Decision to produce
= incompatible with
Decisions (by households) to consume

Number of jobs decided by firms
= incompatible with
Number of workers decided by
households

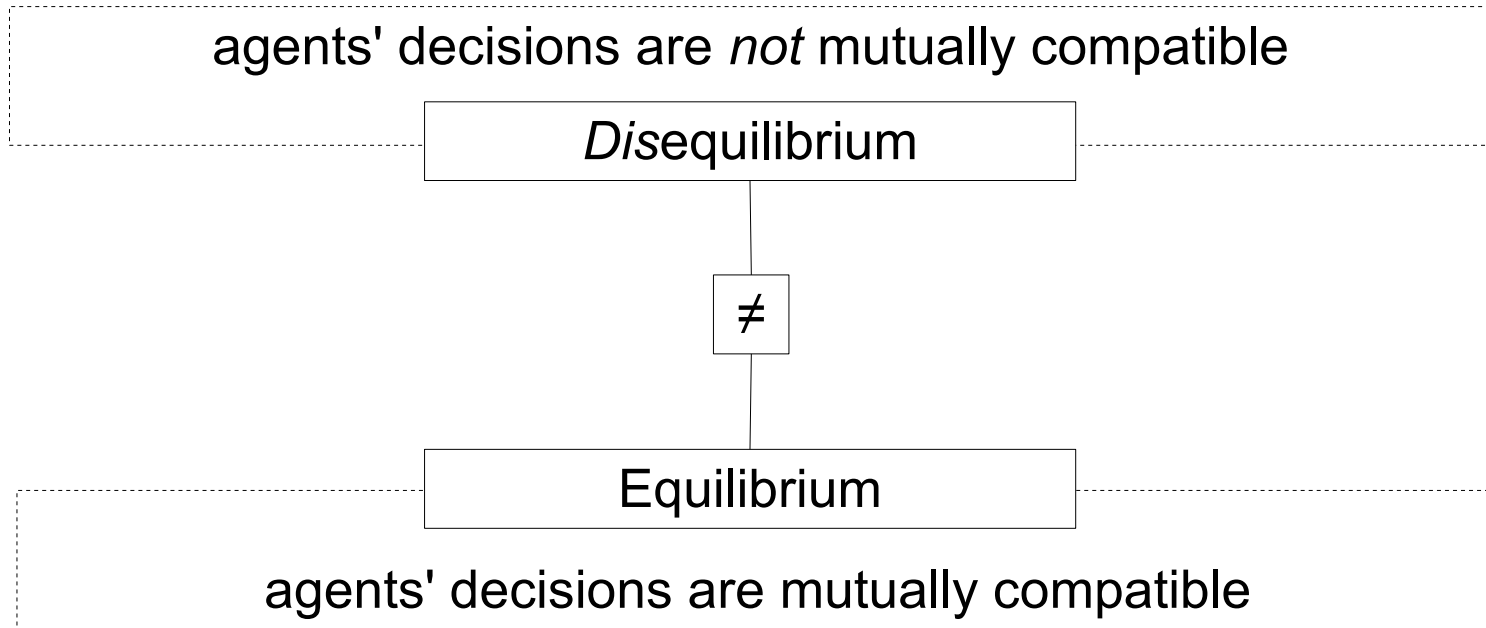

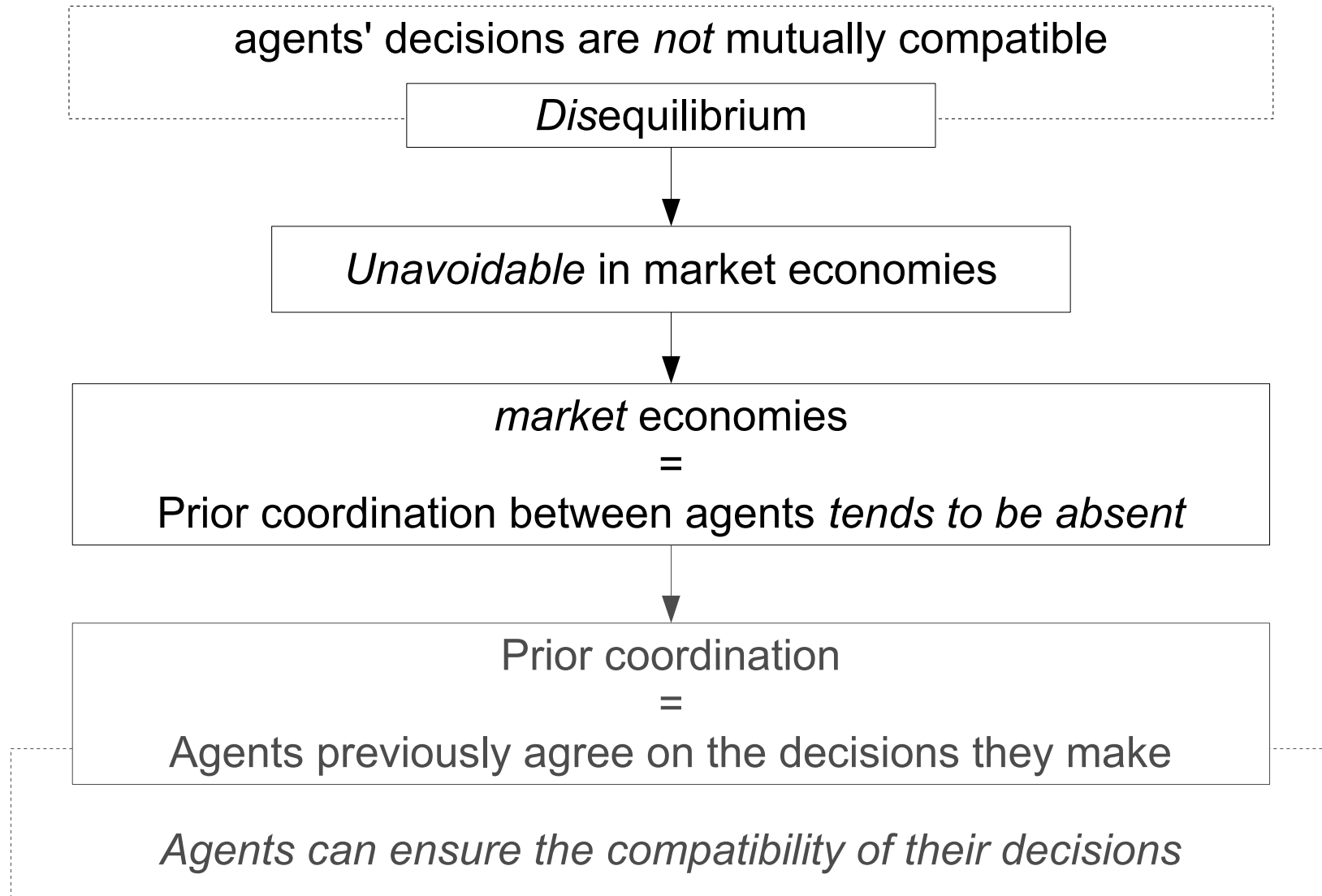

Disequilibrium dynamics

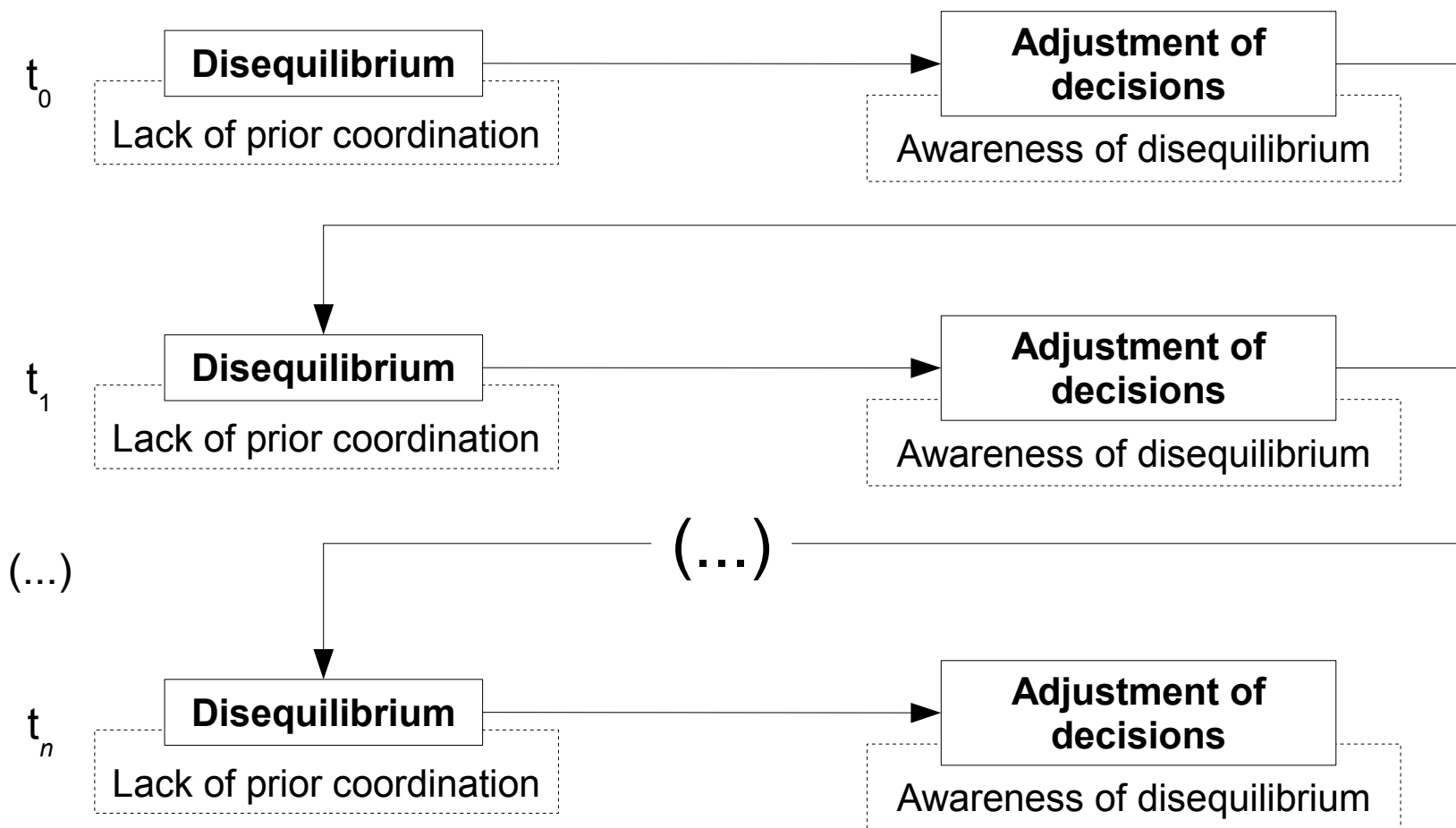

Disequilibrium dynamics and mainstream economics: the question of stability

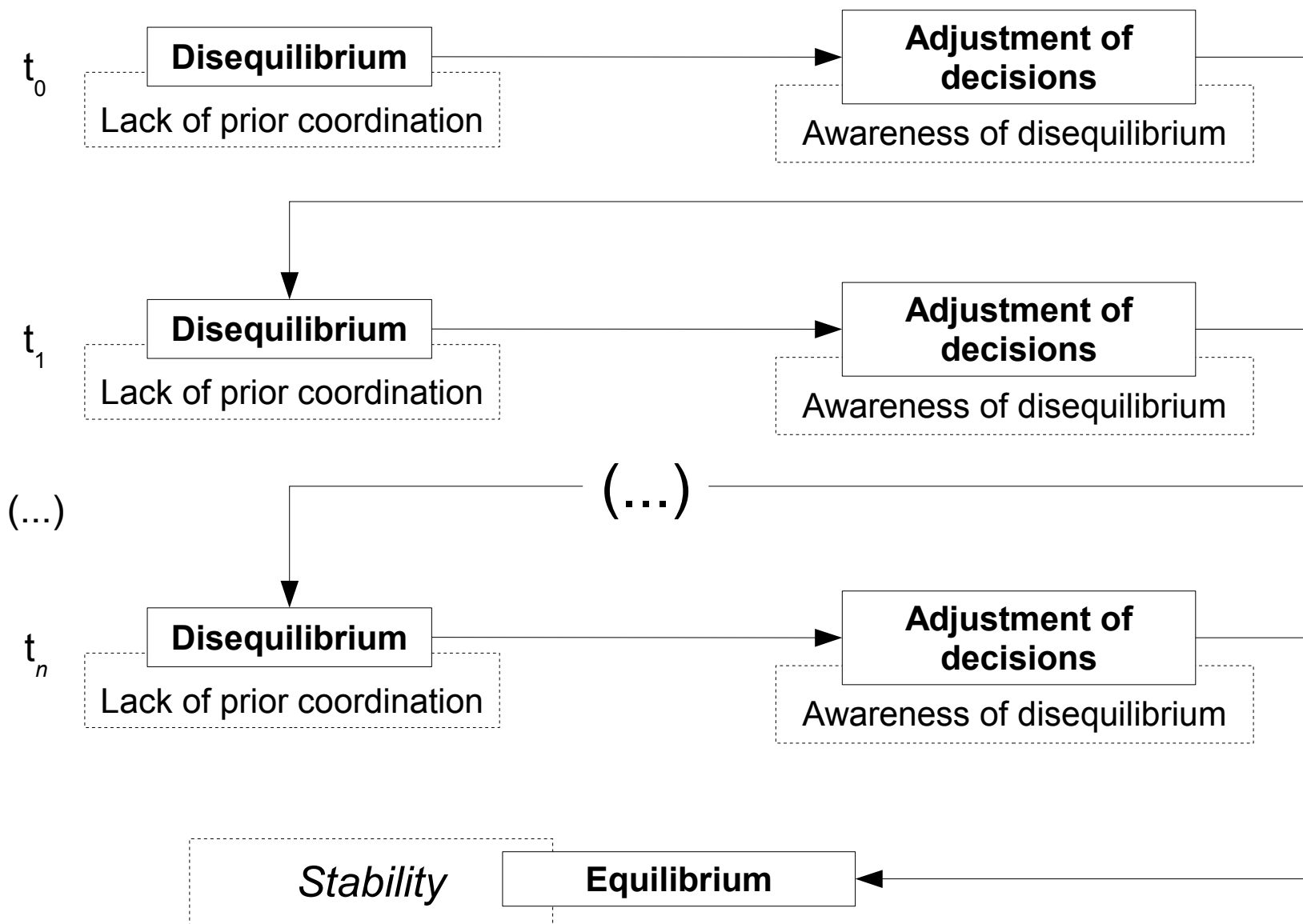

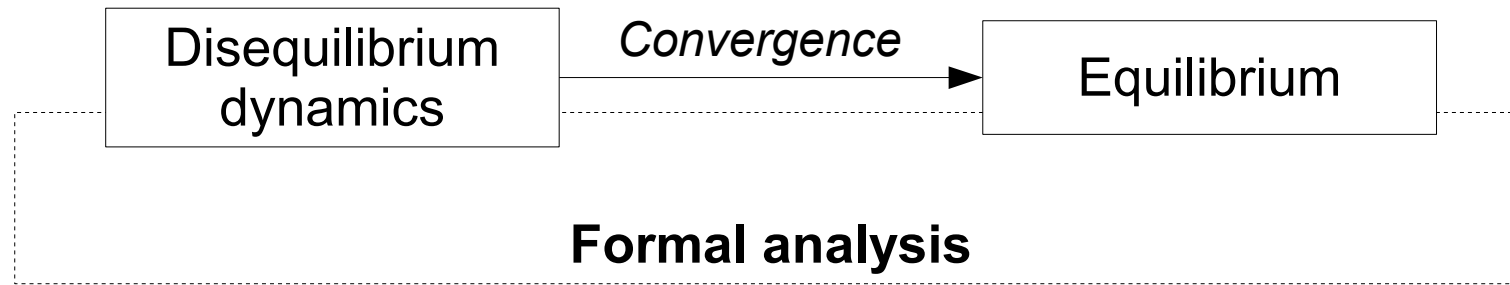

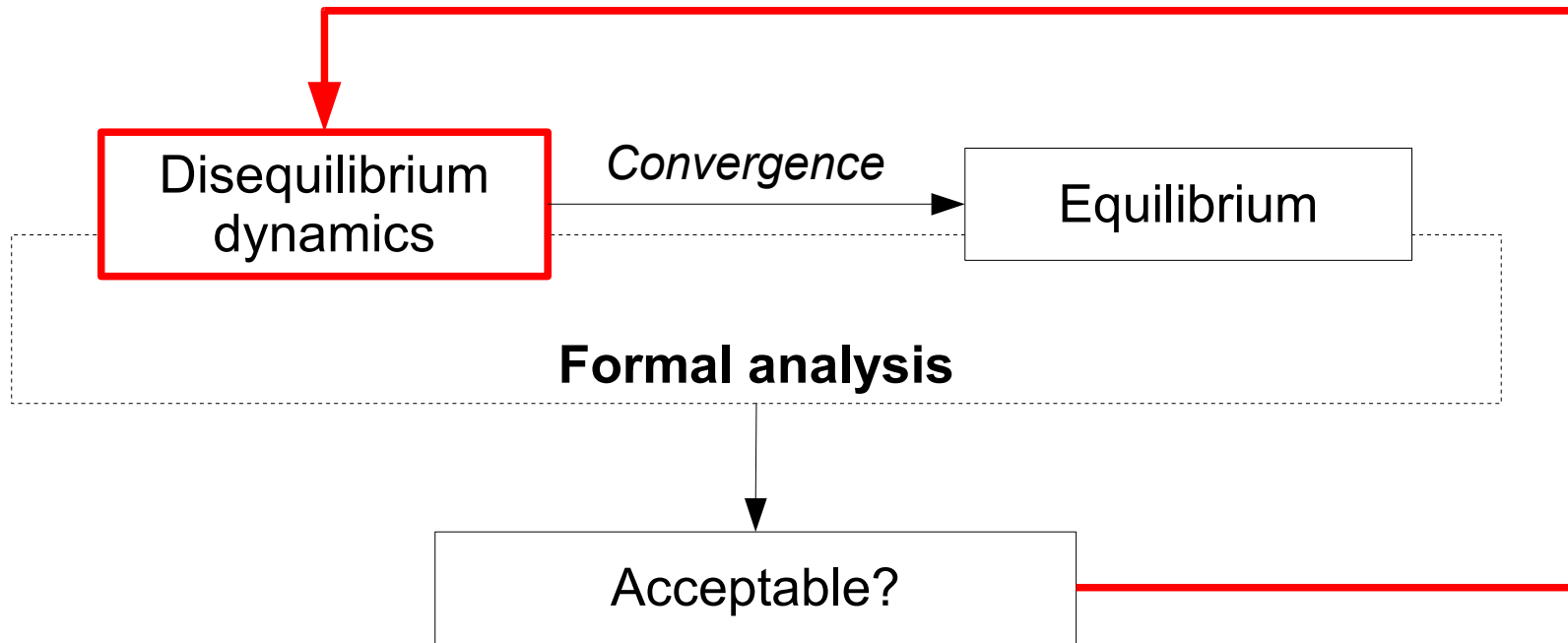

Formal analysis

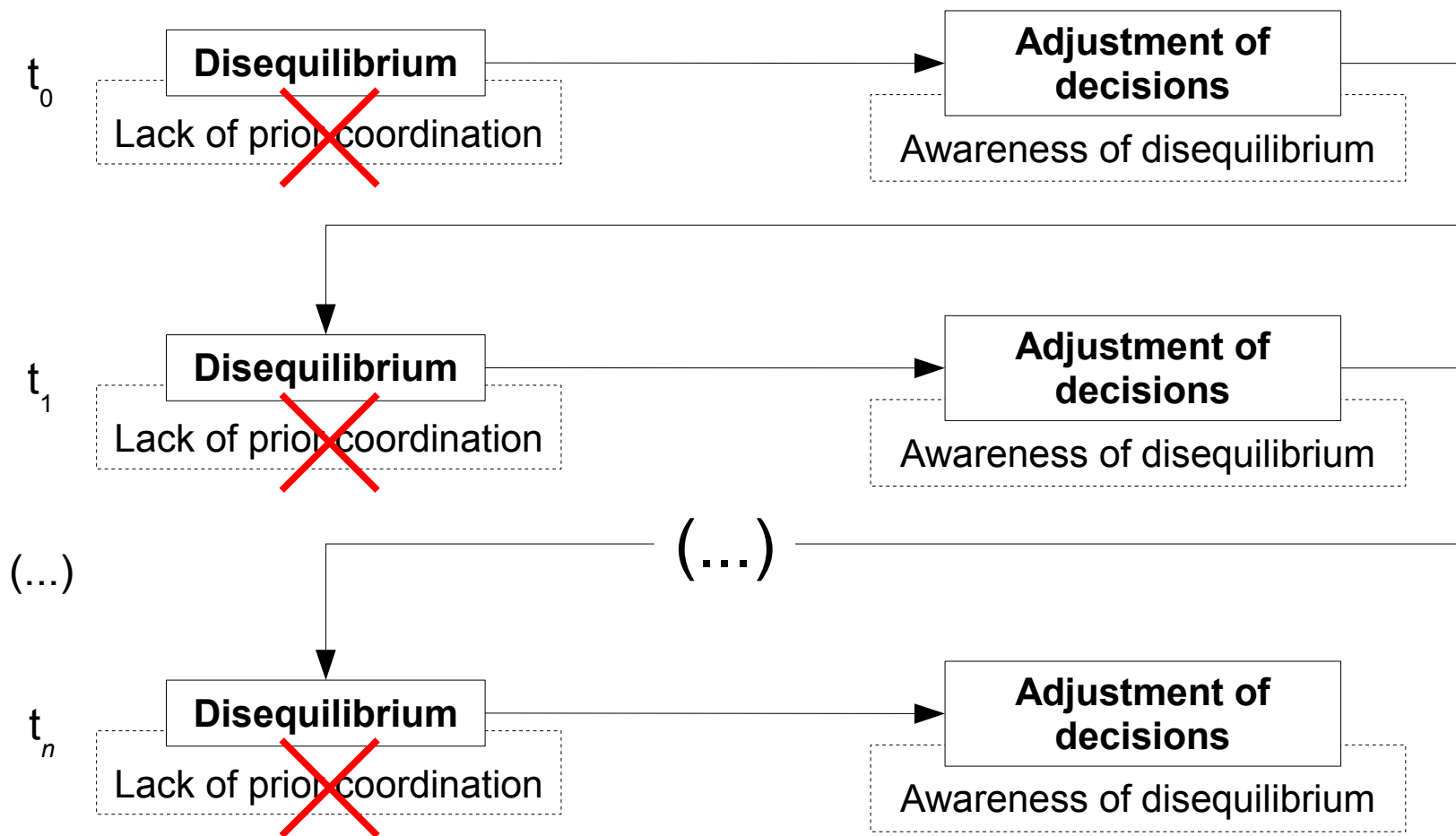

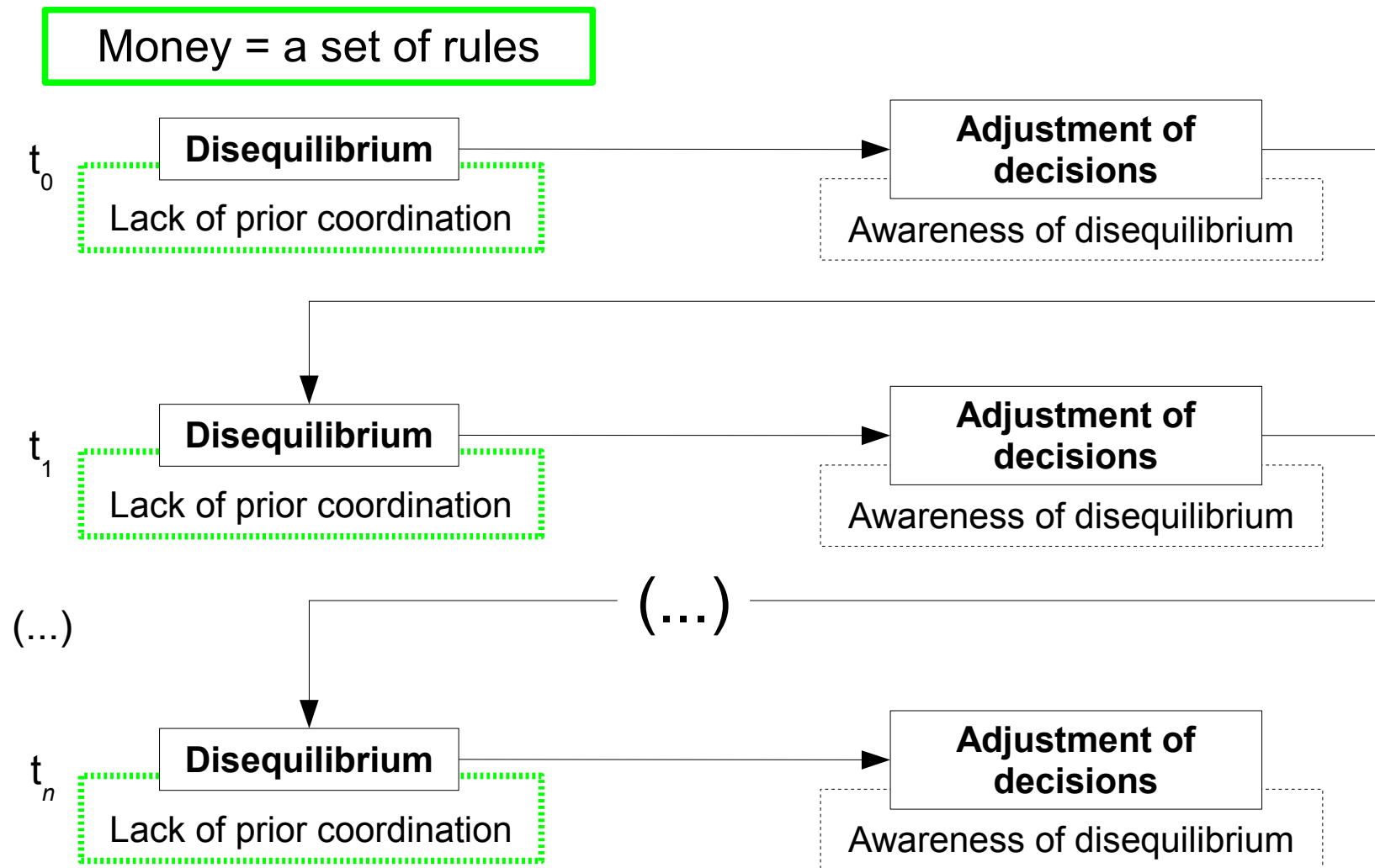

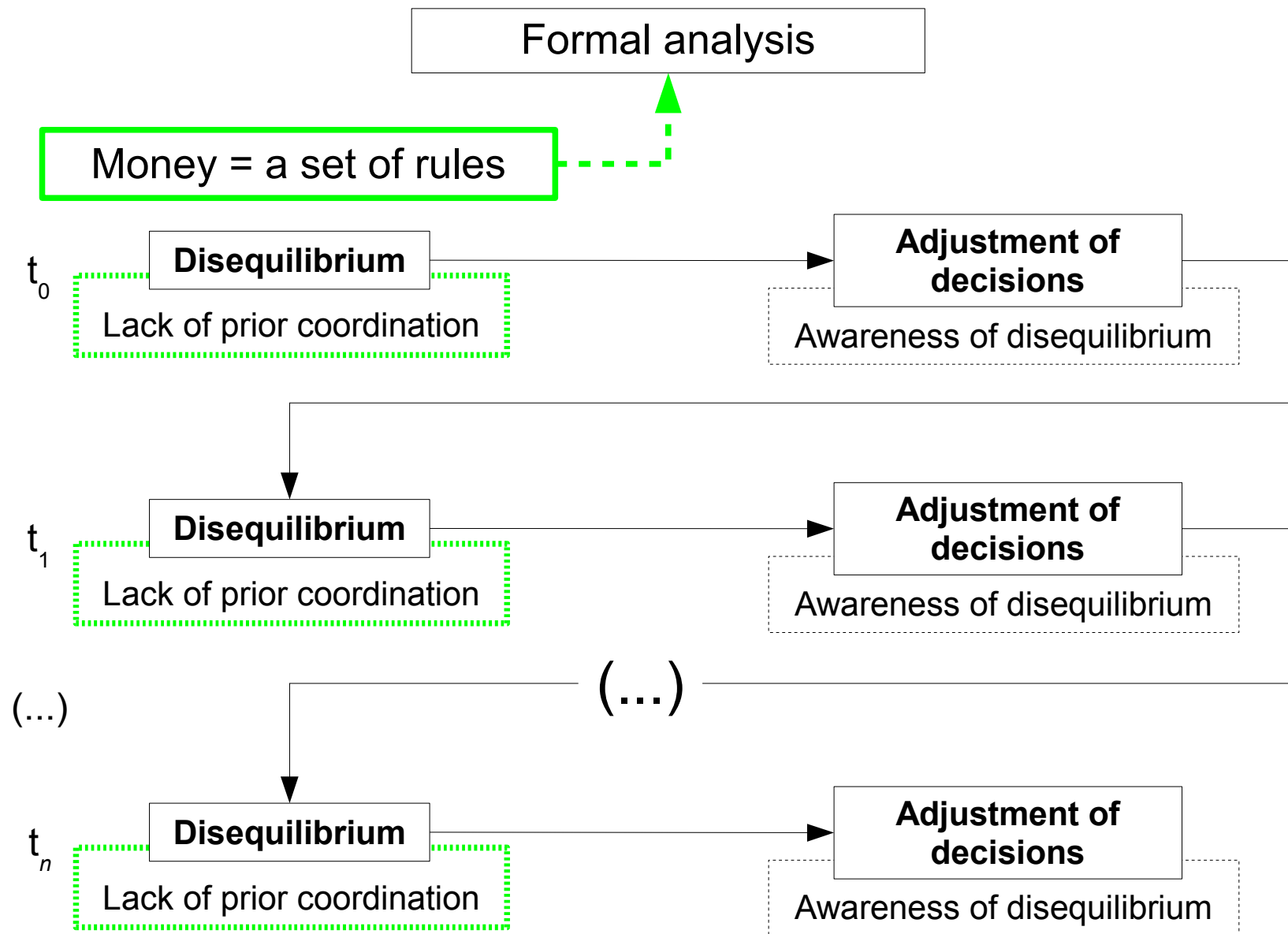

I. Disequilibrium dynamics and *tâtonnement*

1.

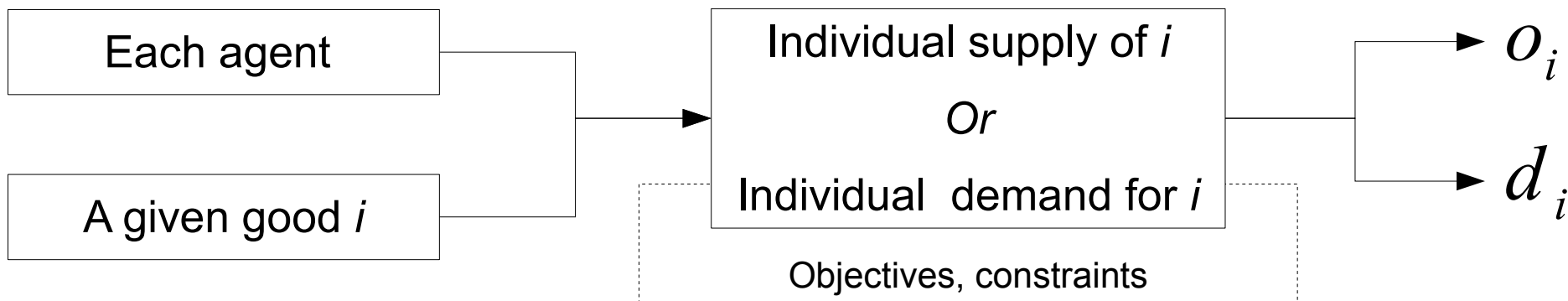

2.

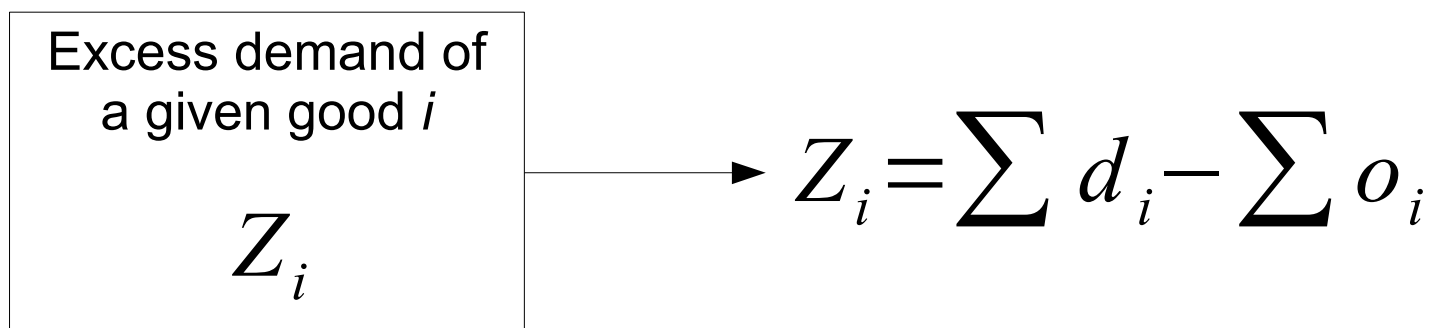

I. Disequilibrium dynamics and *tâtonnement*

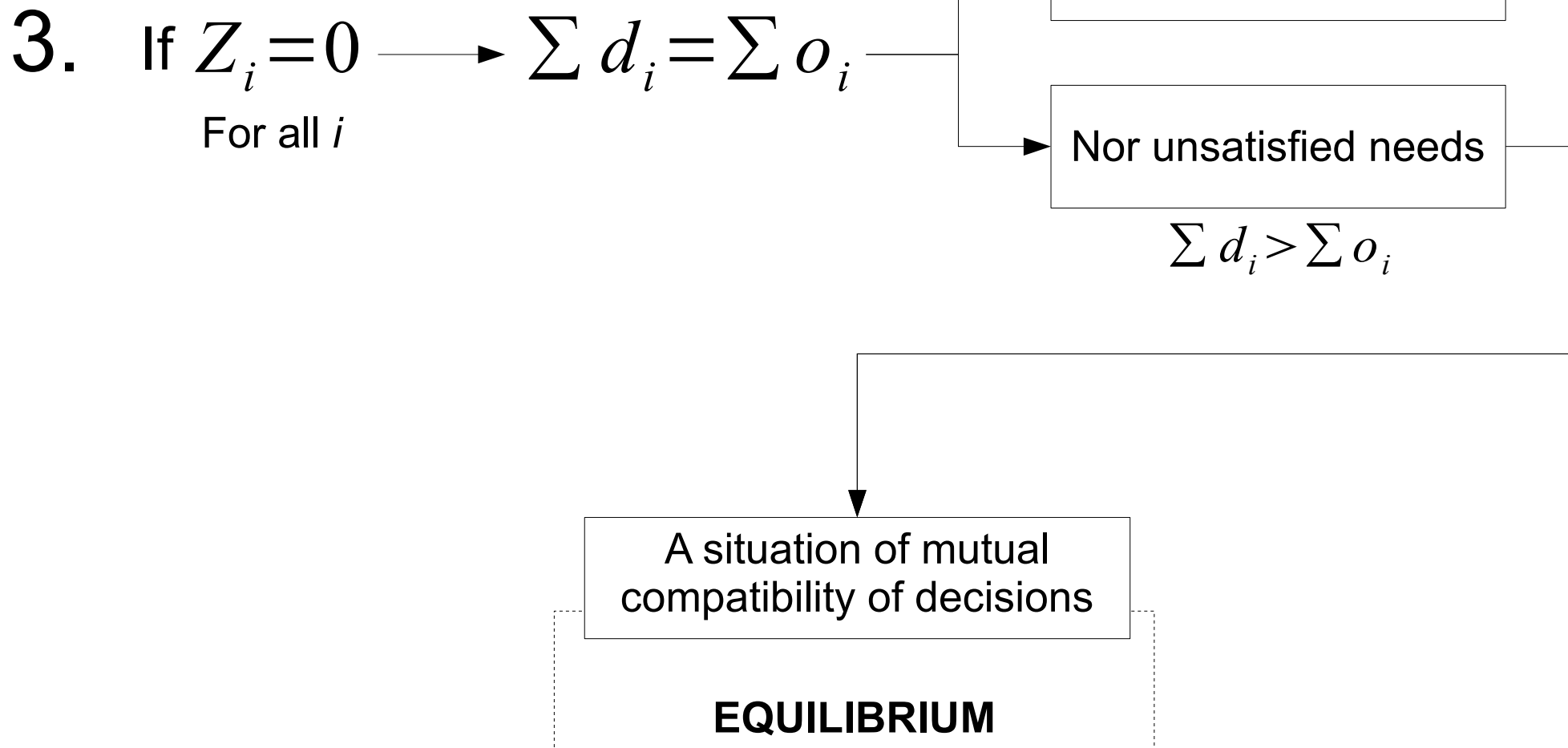

I. Disequilibrium dynamics and *tâtonnement*

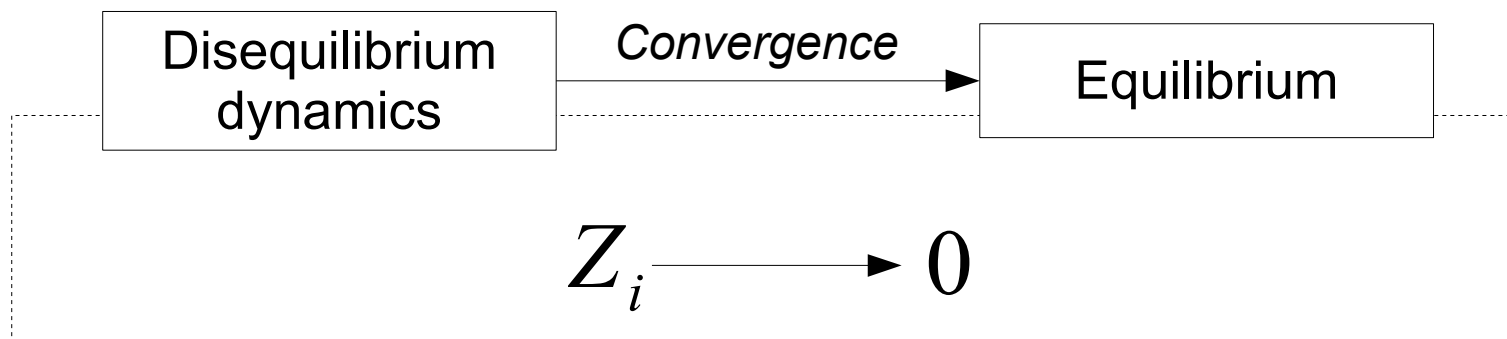

I. Disequilibrium dynamics and *tâtonnement*

4.

Price variations

$$Z_i \longrightarrow 0$$

$$Z_i = \sum d_i - \sum o_i$$

$$\uparrow p_i \longrightarrow \downarrow d_i$$

$$\uparrow p_i \longrightarrow \uparrow o_i$$

I. Disequilibrium dynamics and *tâtonnement*

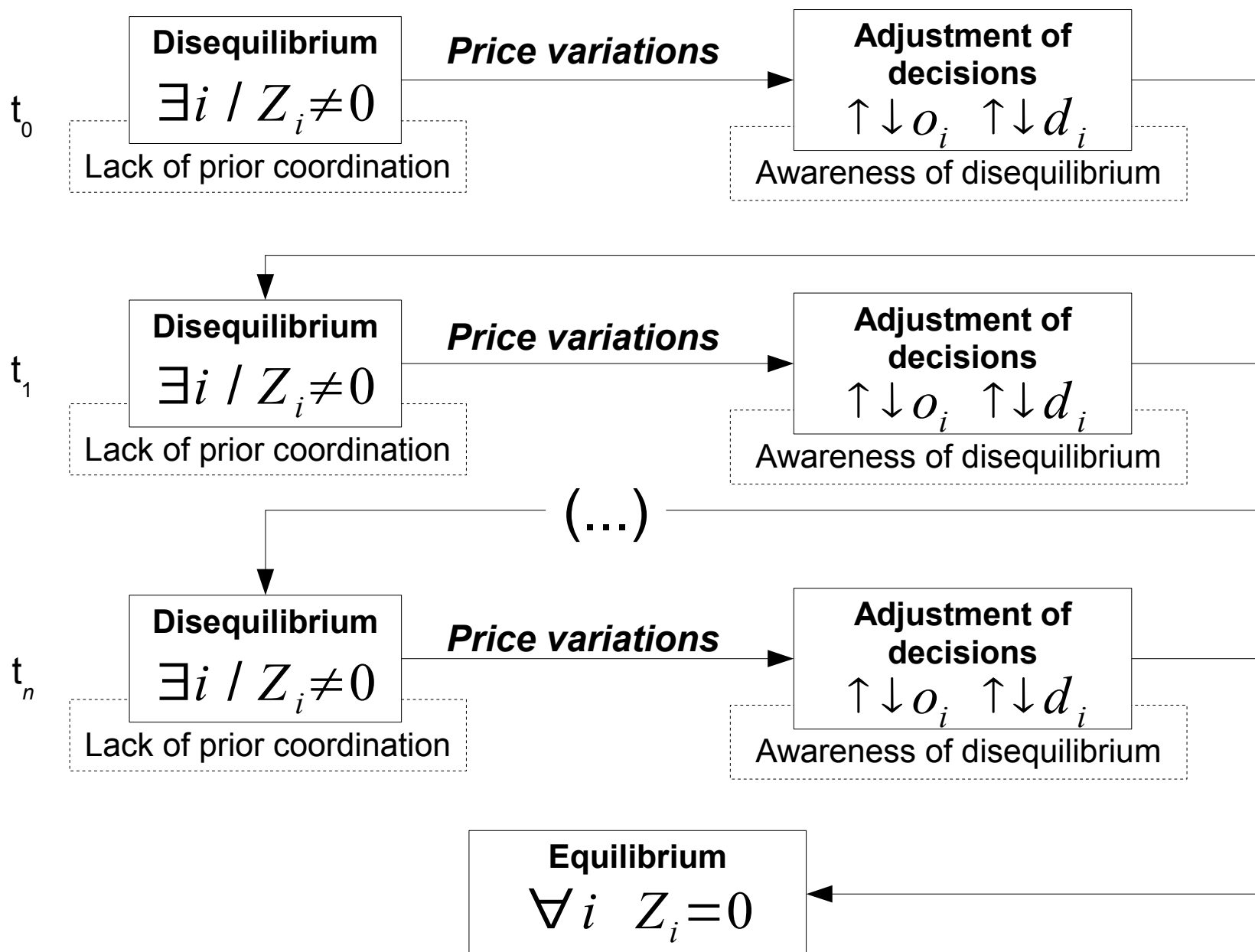

I. Disequilibrium dynamics and *tâtonnement*

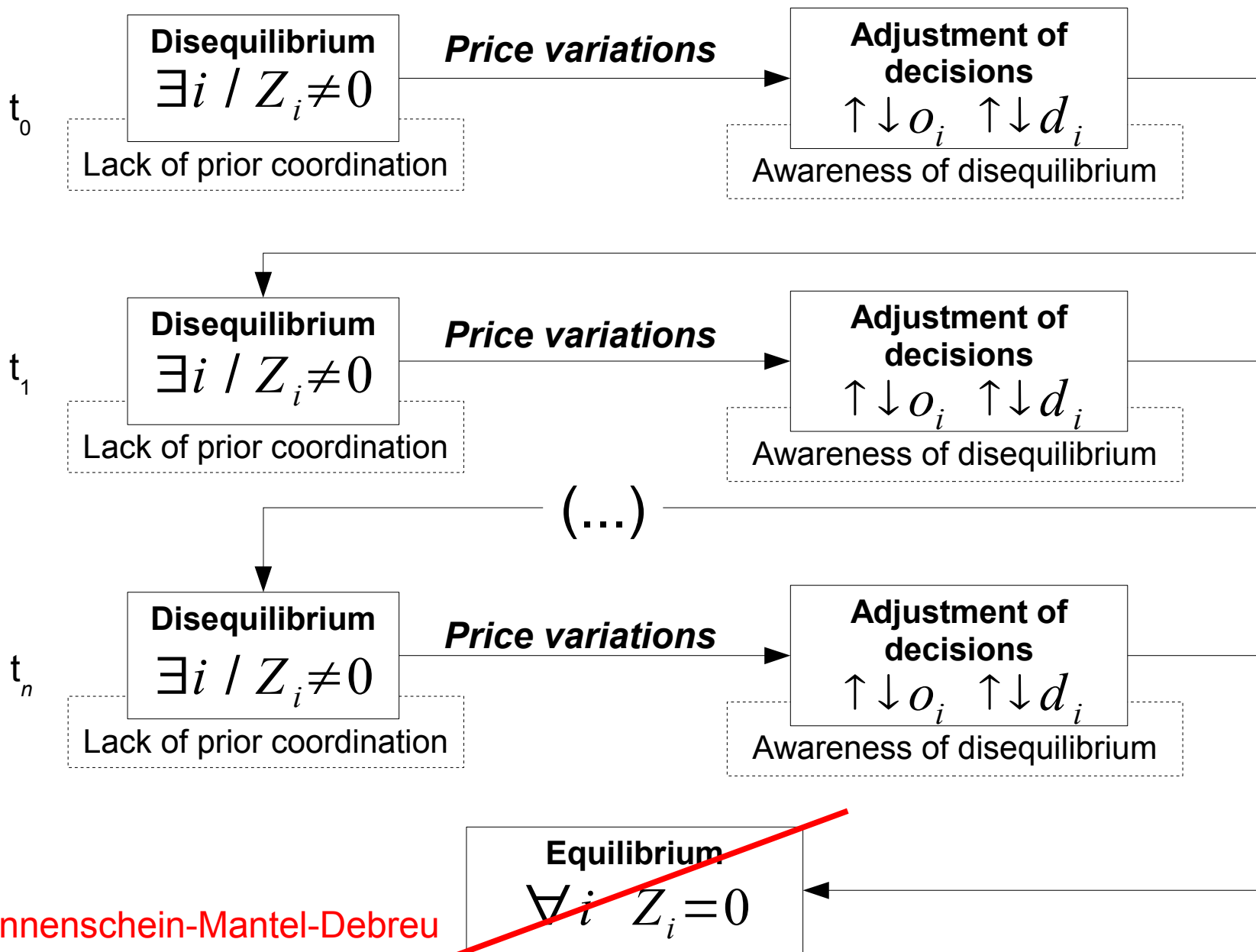

I. Disequilibrium dynamics and *tâtonnement*

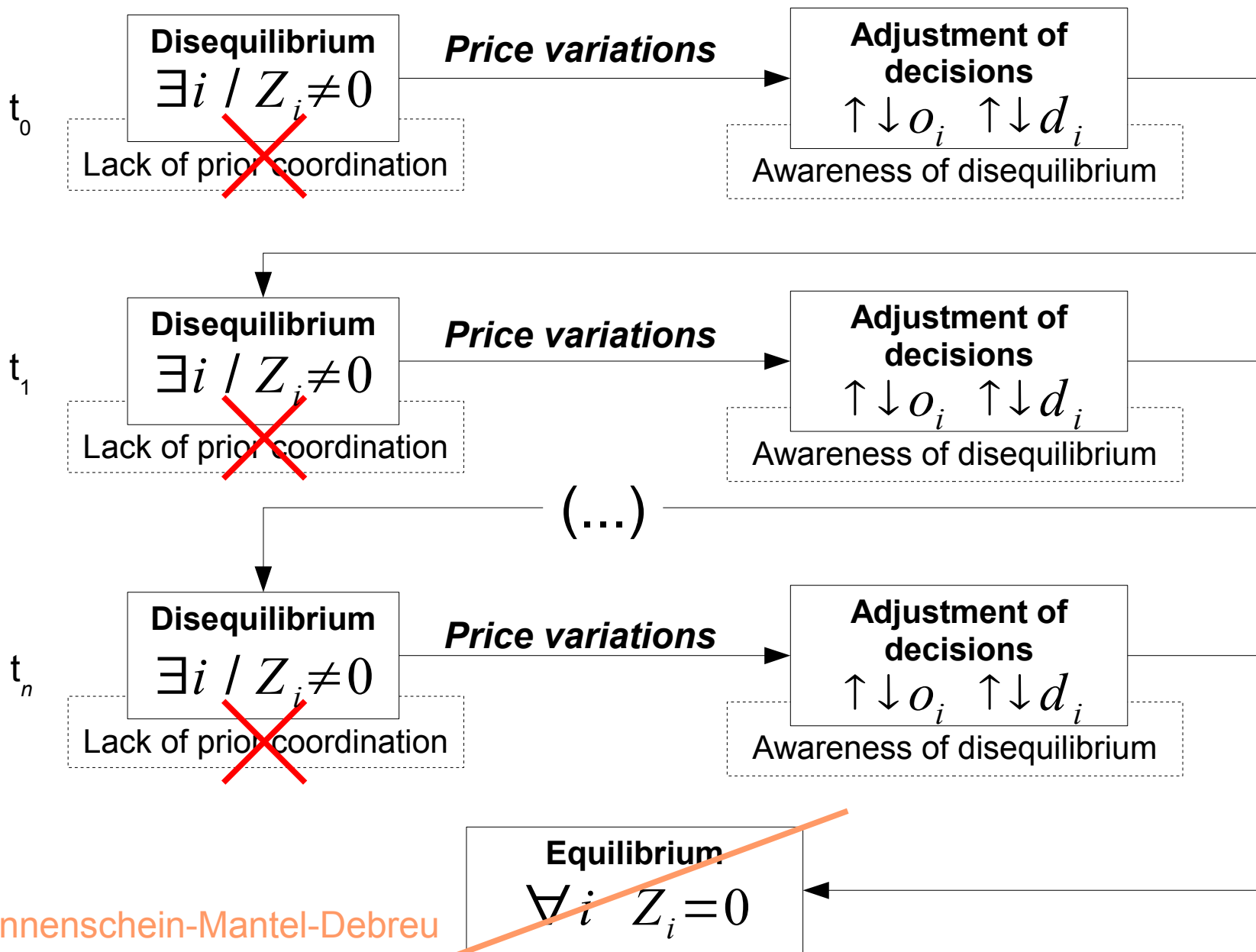

I. Disequilibrium dynamics and *tâtonnement*

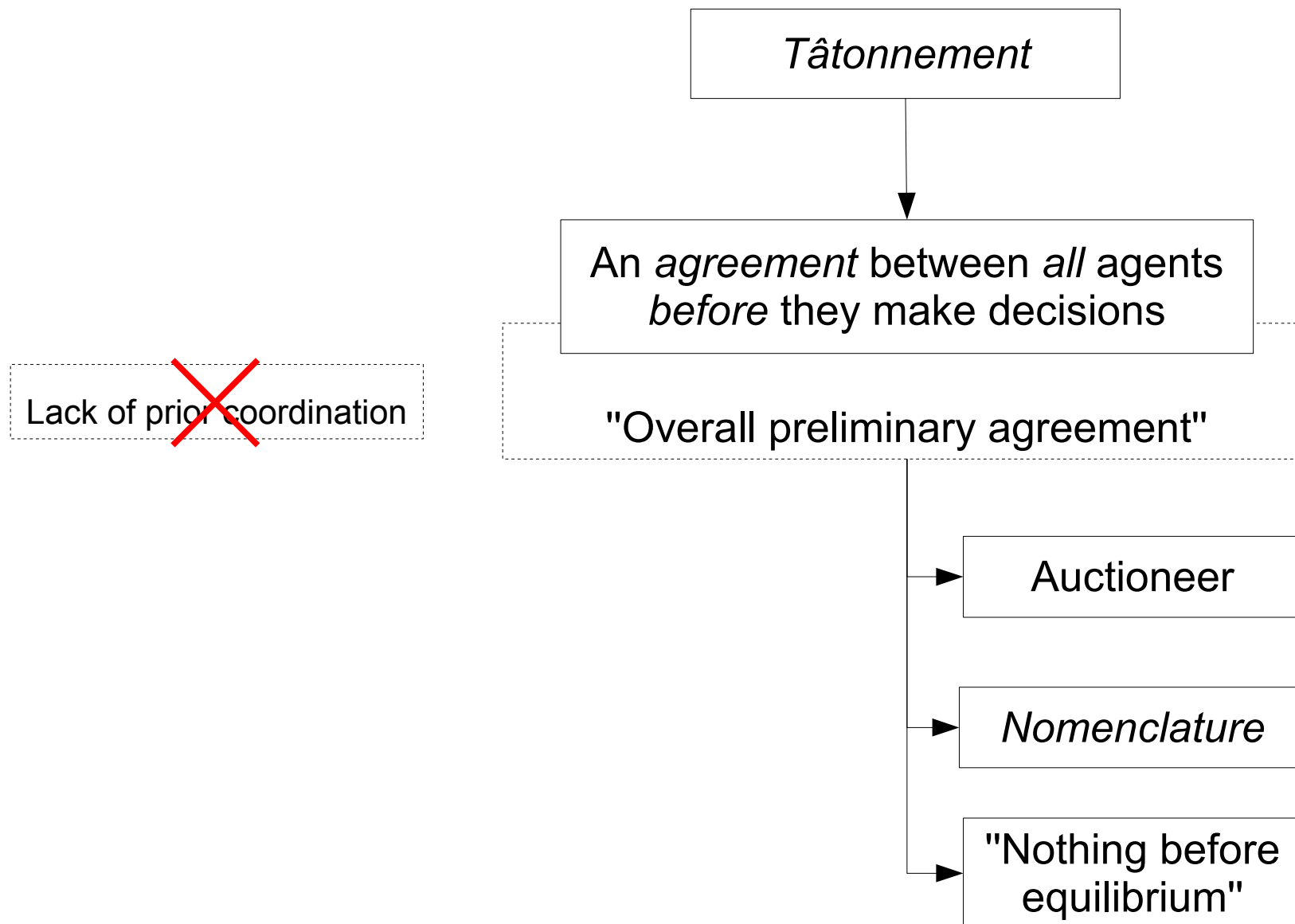

I. Disequilibrium dynamics and *tâtonnement*

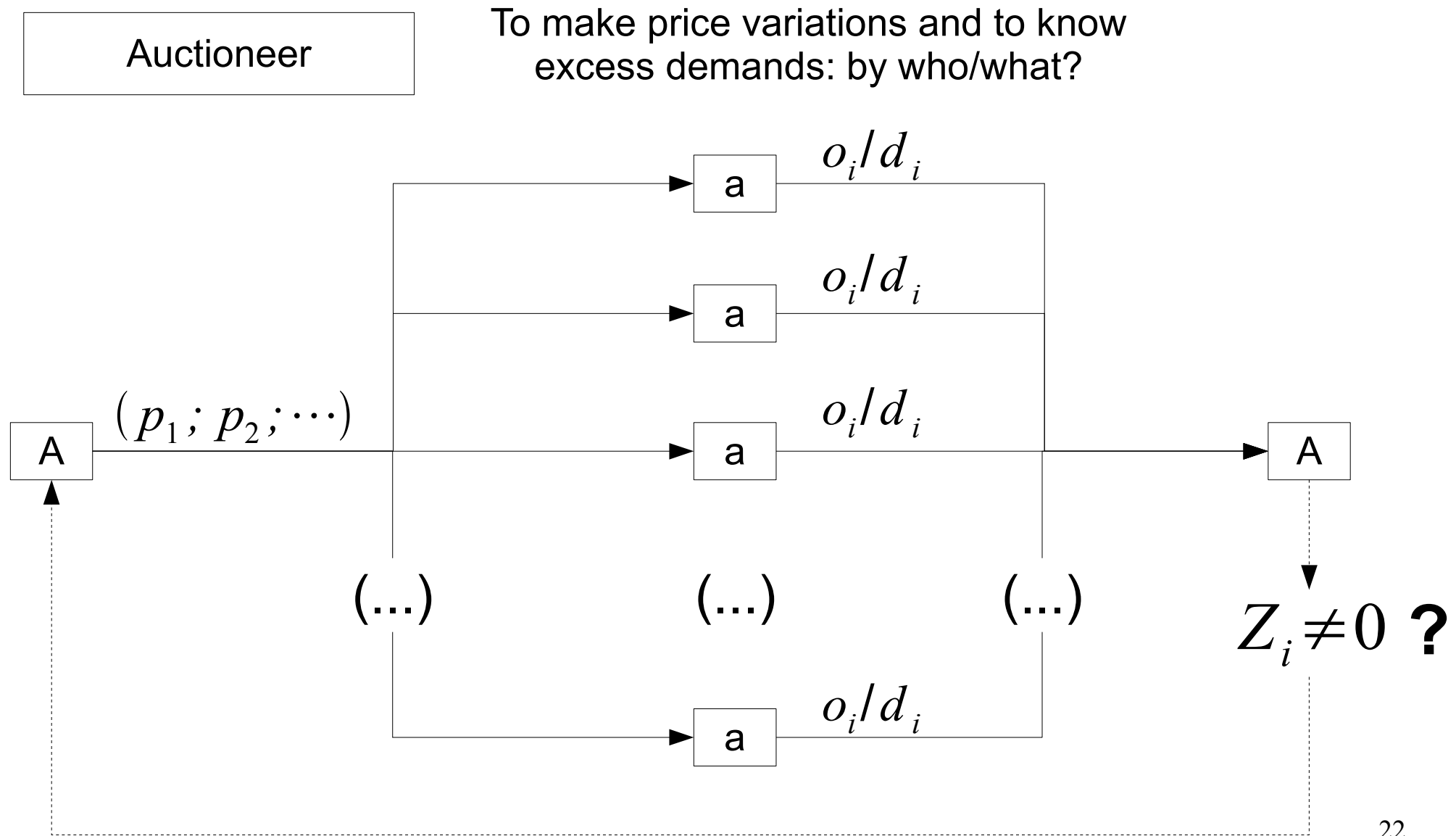

I. Disequilibrium dynamics and *tâtonnement*

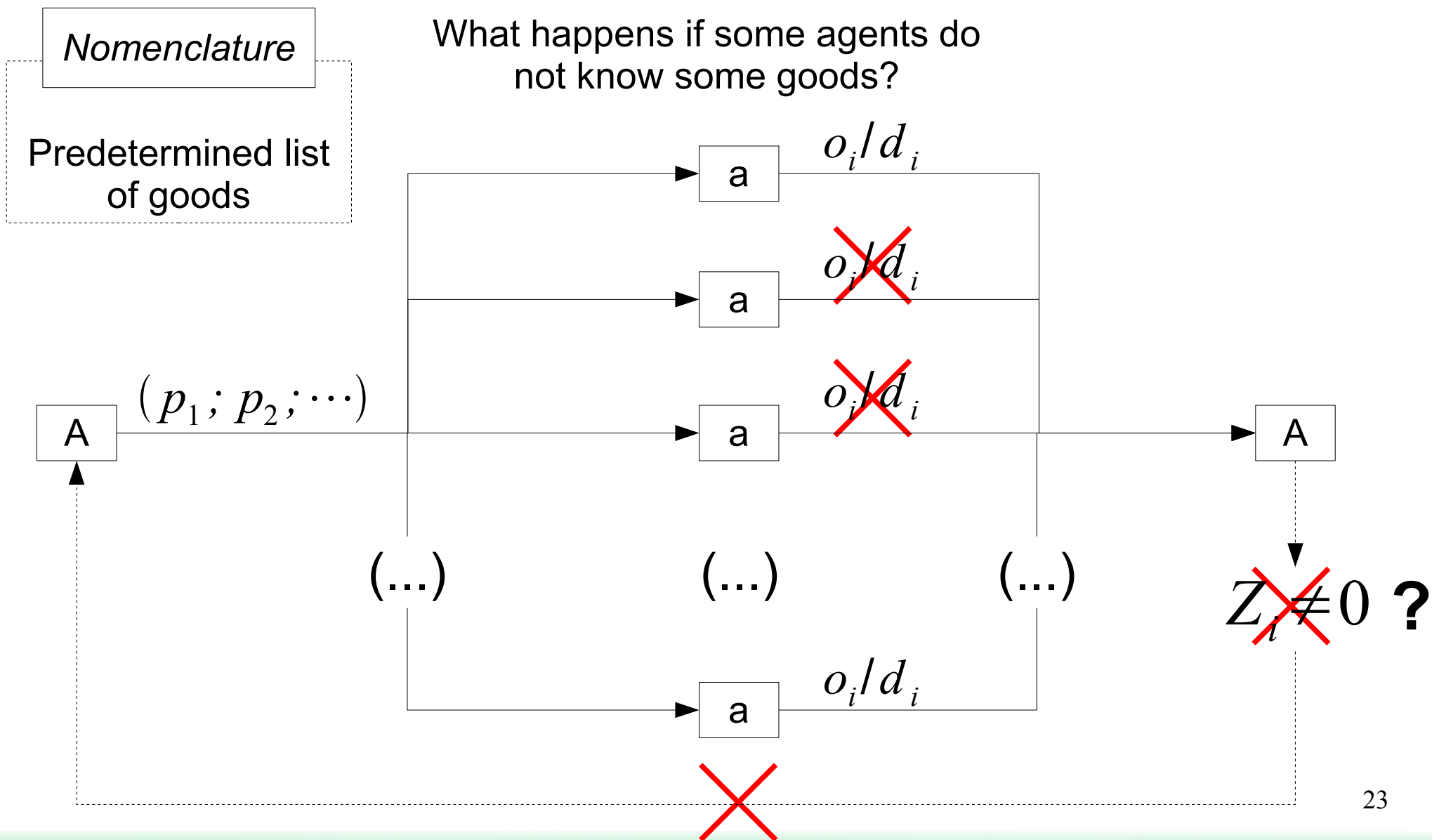

I. Disequilibrium dynamics and *tâtonnement*

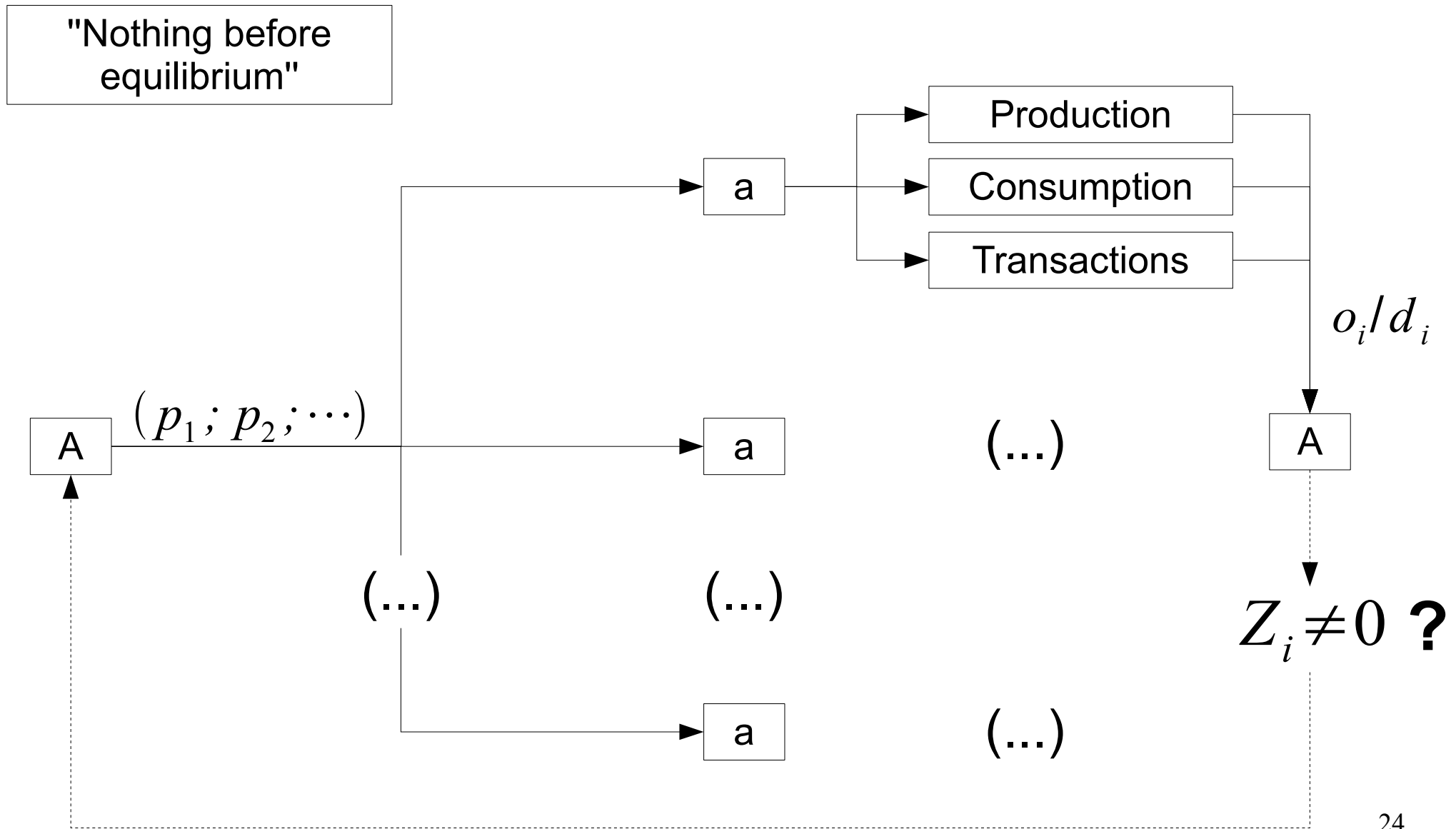

I. Disequilibrium dynamics and *tâtonnement*

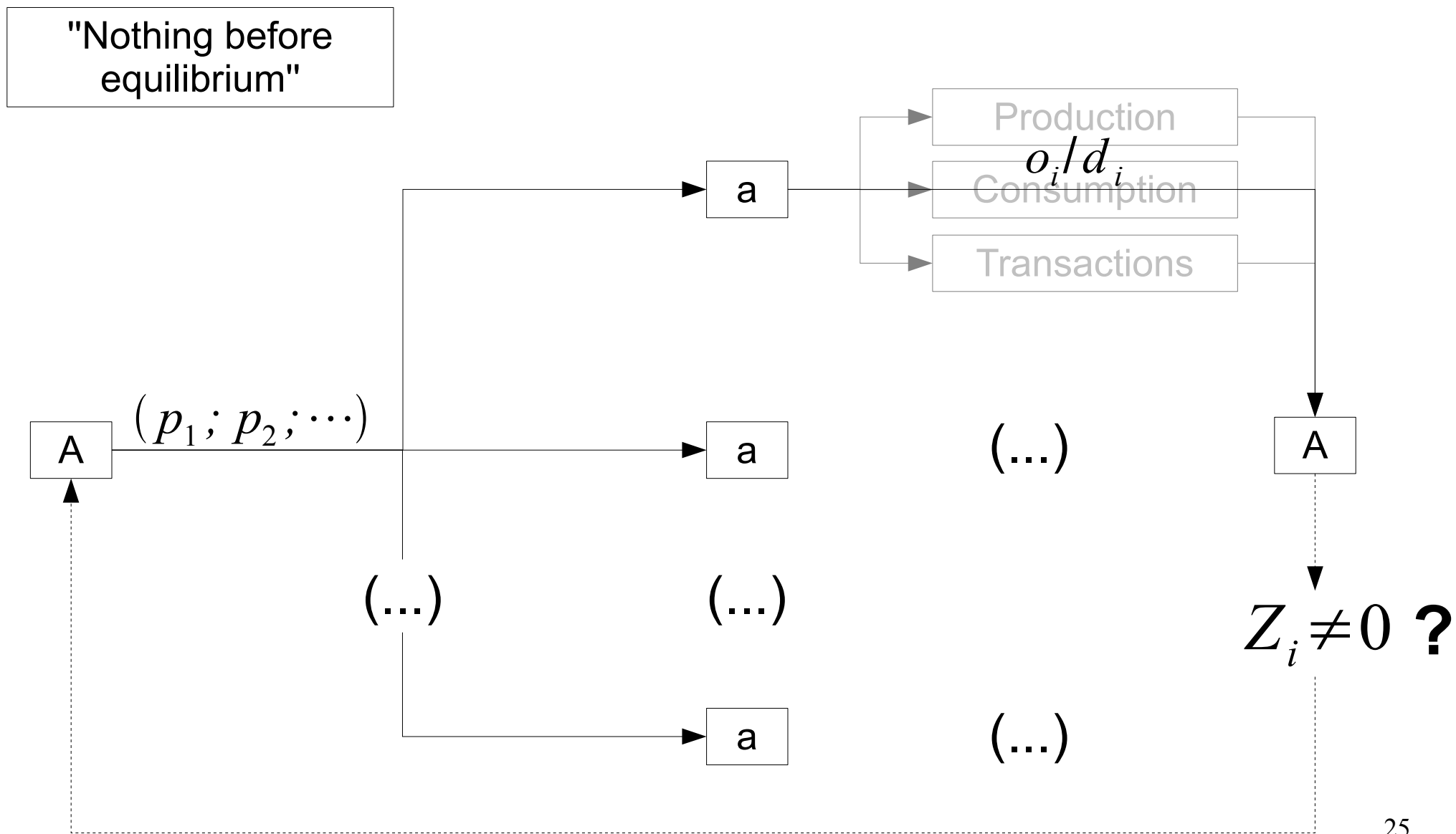

I. Disequilibrium dynamics and *tâtonnement*

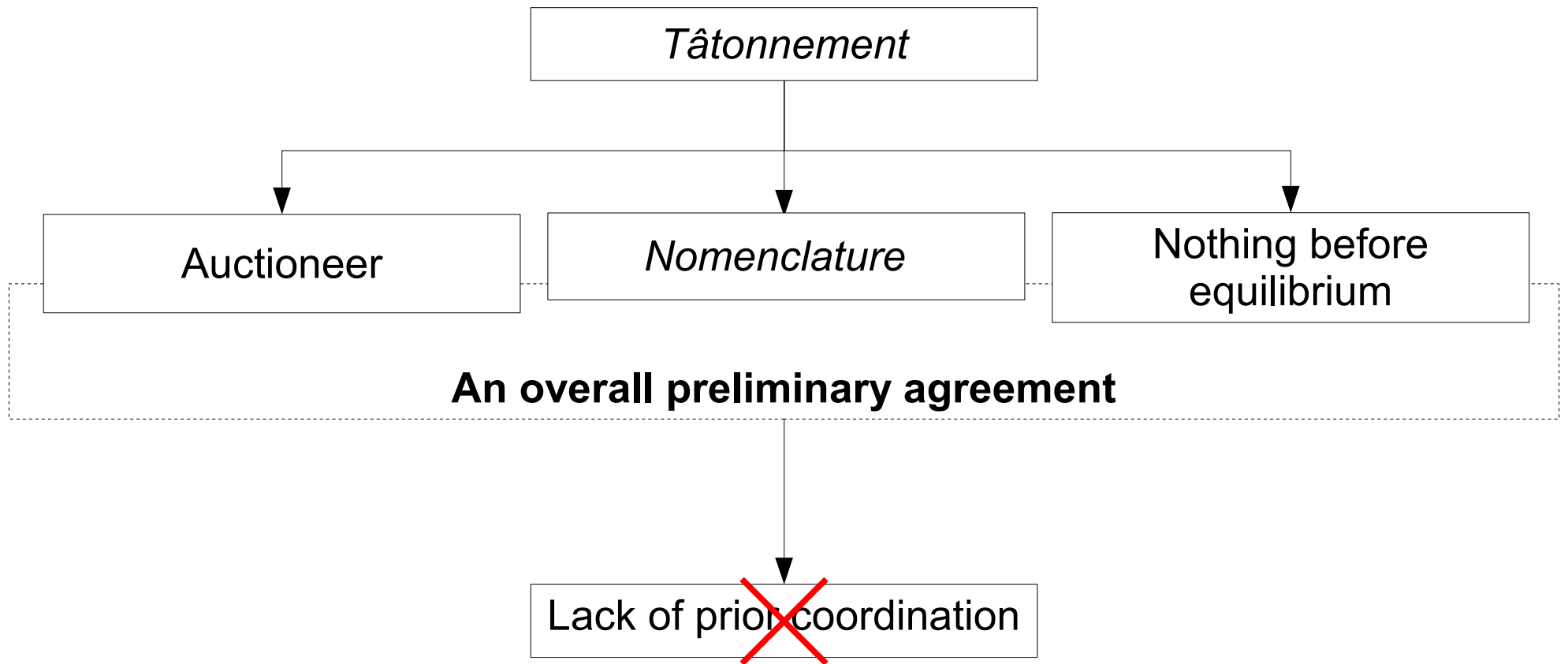

II. Disequilibrium dynamics and money

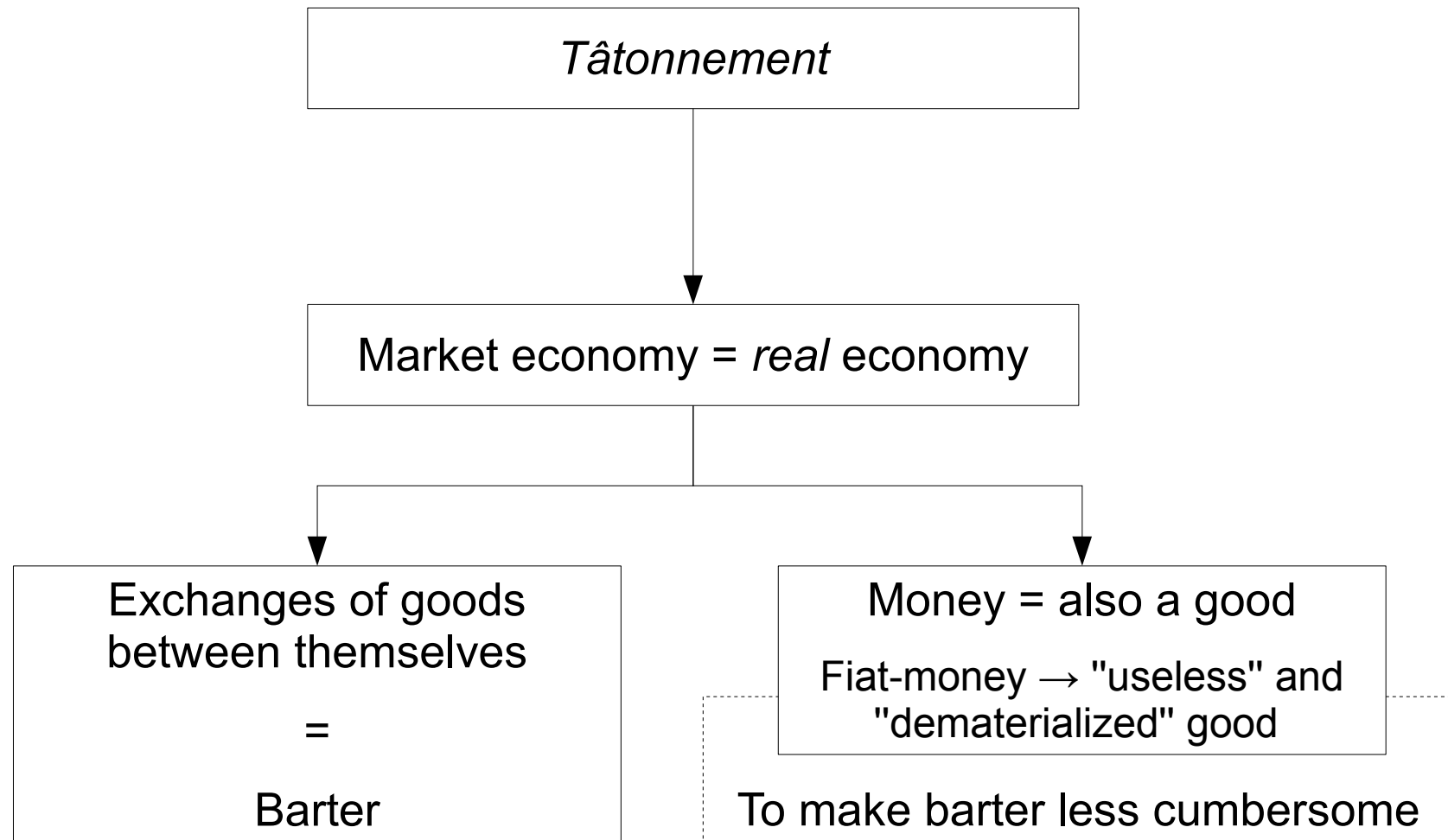

II. Disequilibrium dynamics and money

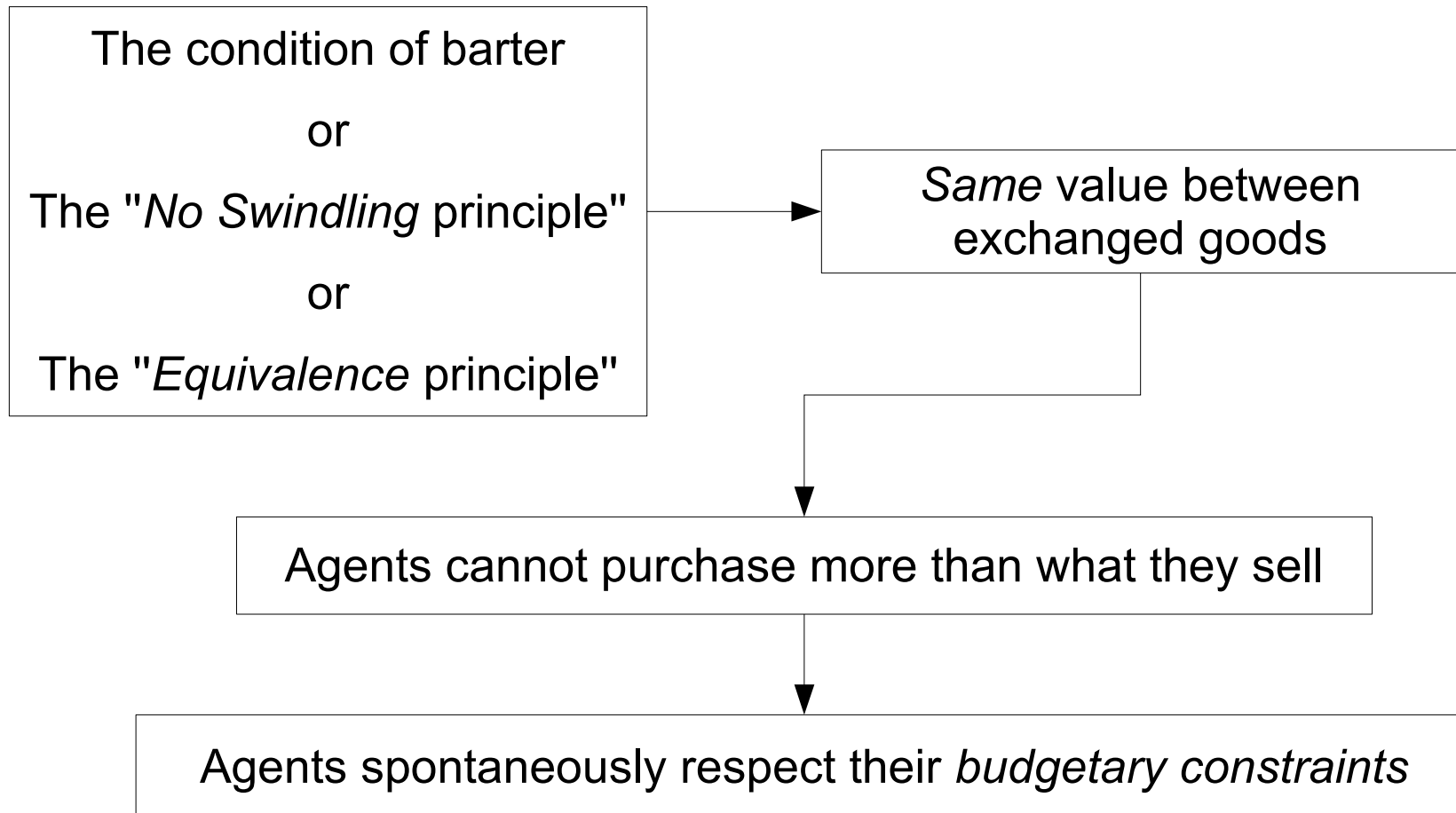

II. Disequilibrium dynamics and money

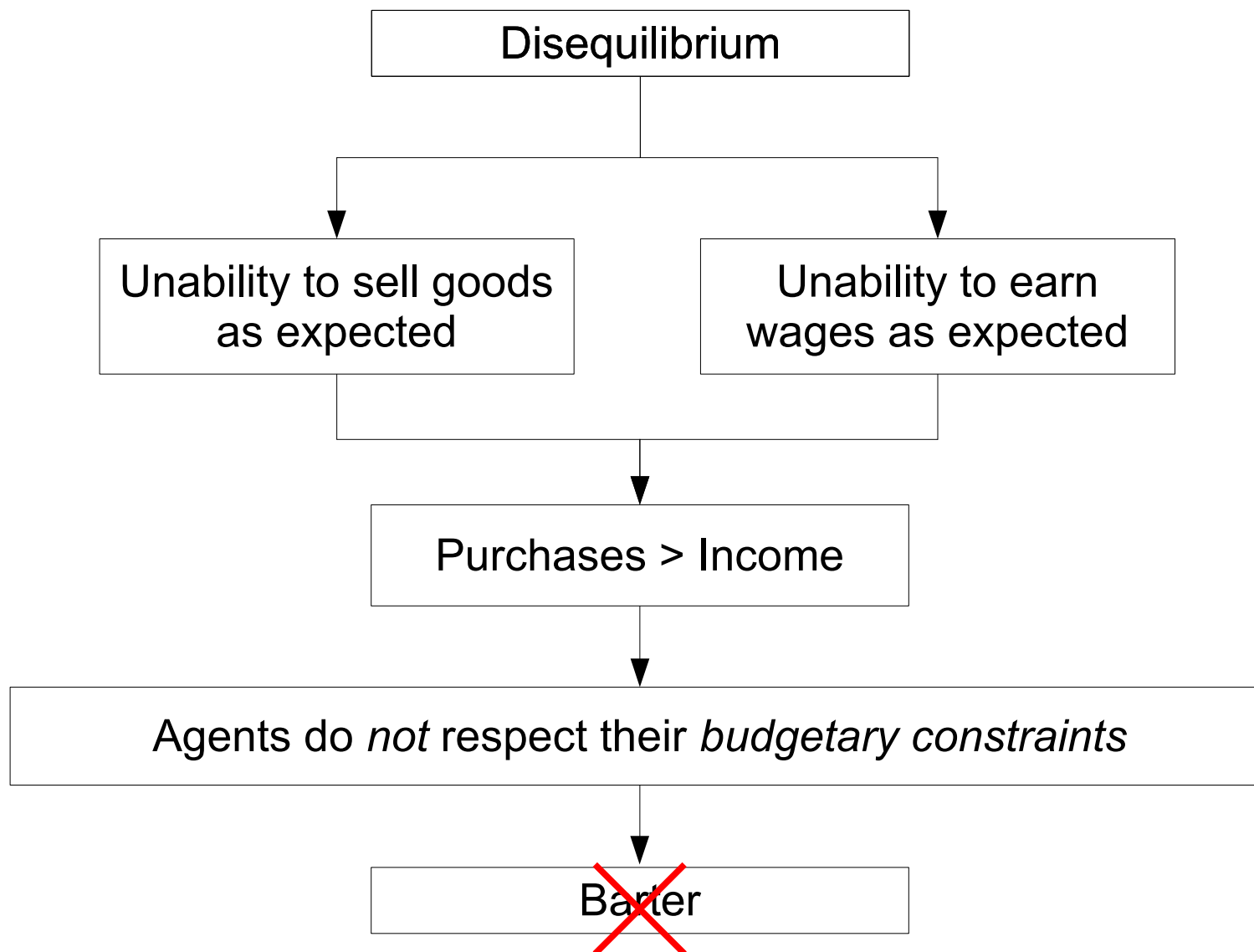

II. Disequilibrium dynamics and money

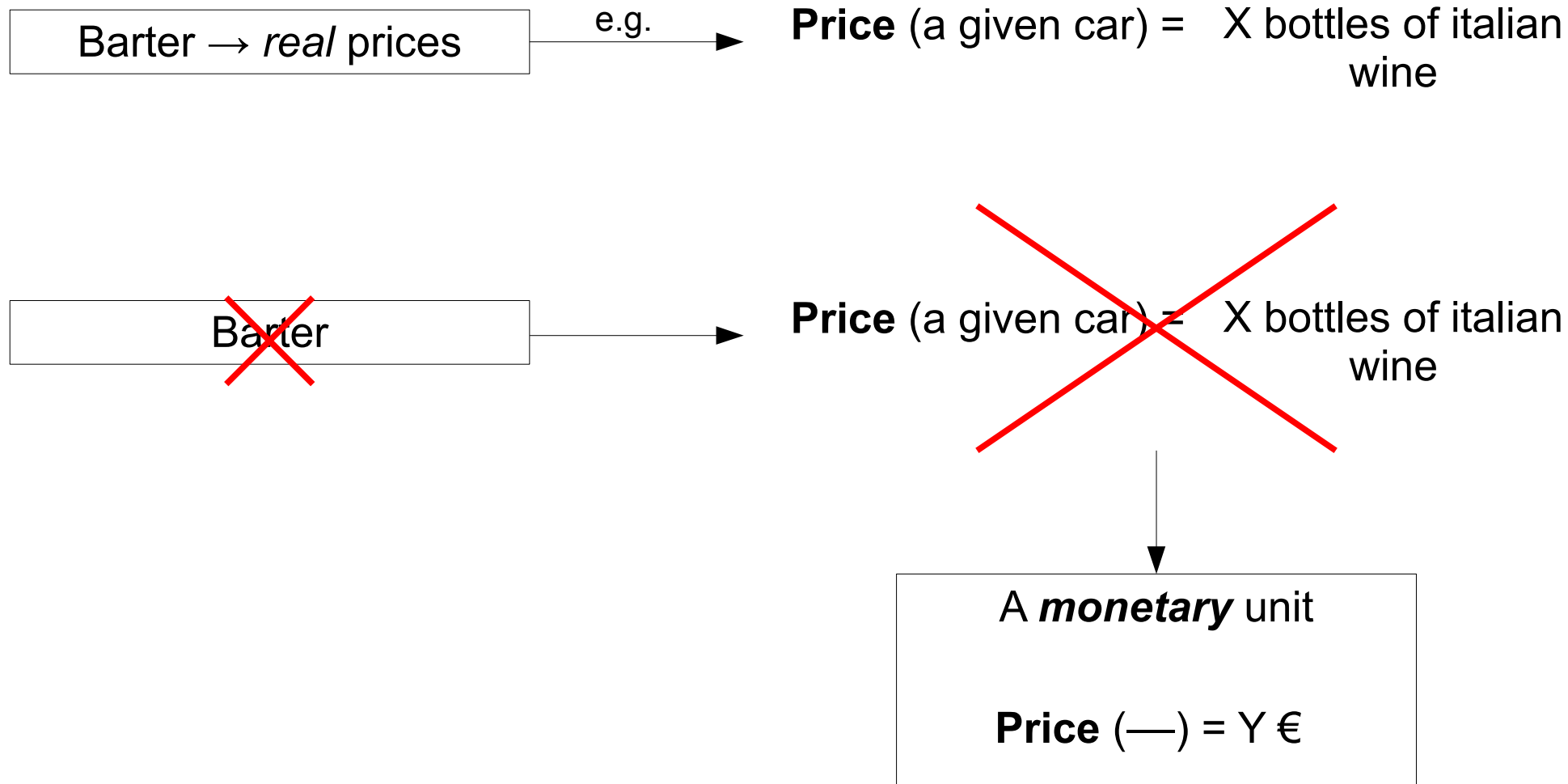

II. Disequilibrium dynamics and money

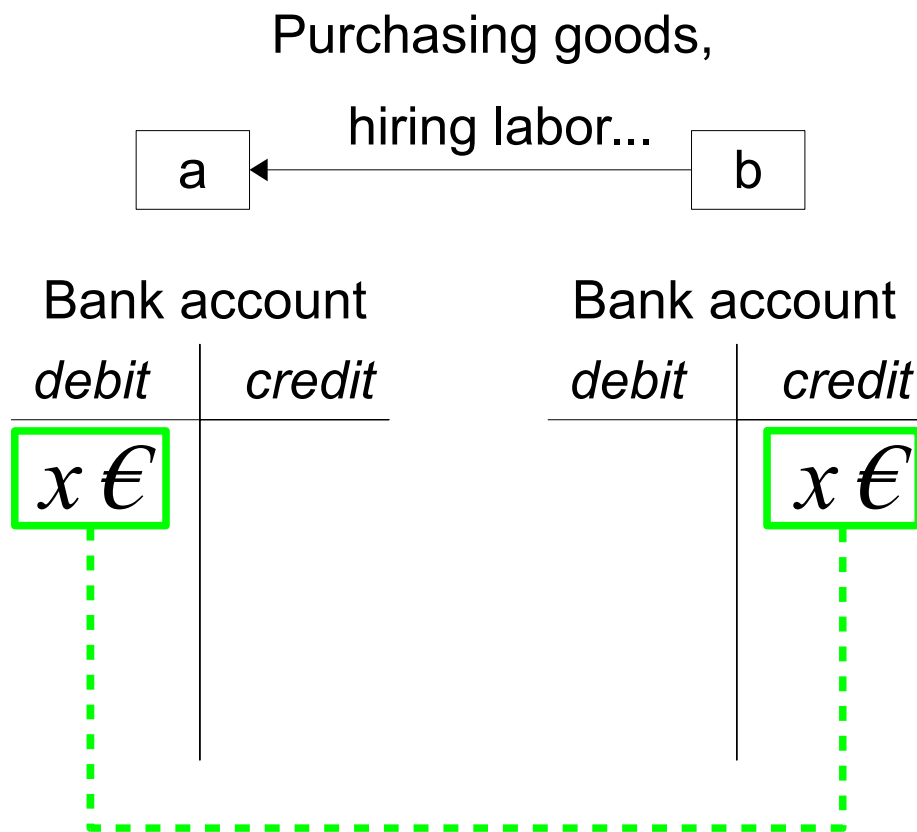

+x€ (credit) / -x€ (debit) = "payment"

II. Disequilibrium dynamics and money

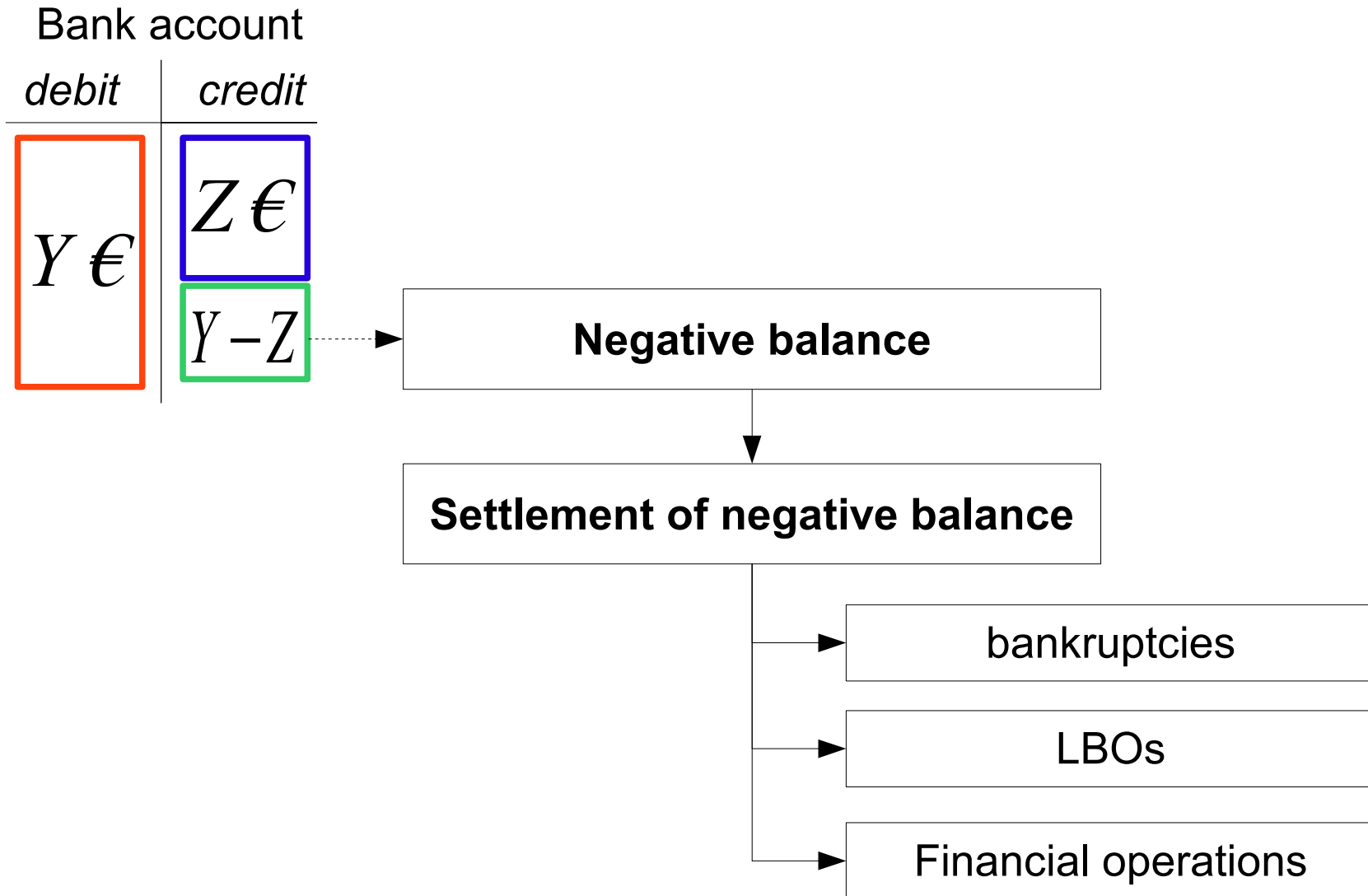

II. Disequilibrium dynamics and money

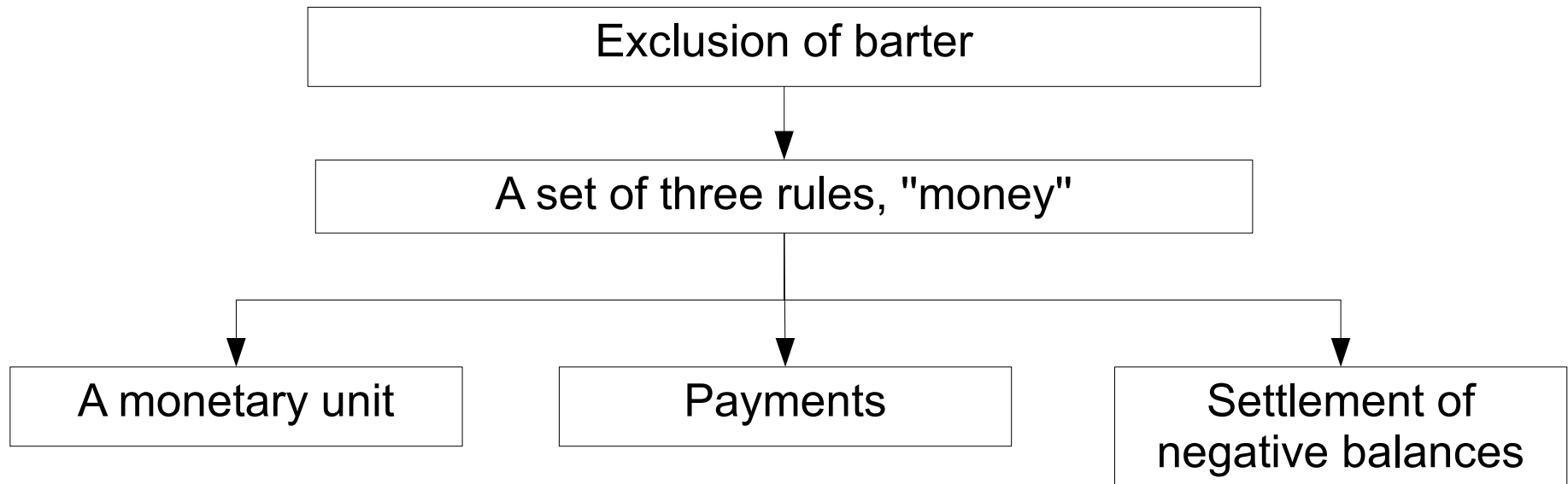

II. Disequilibrium dynamics and money

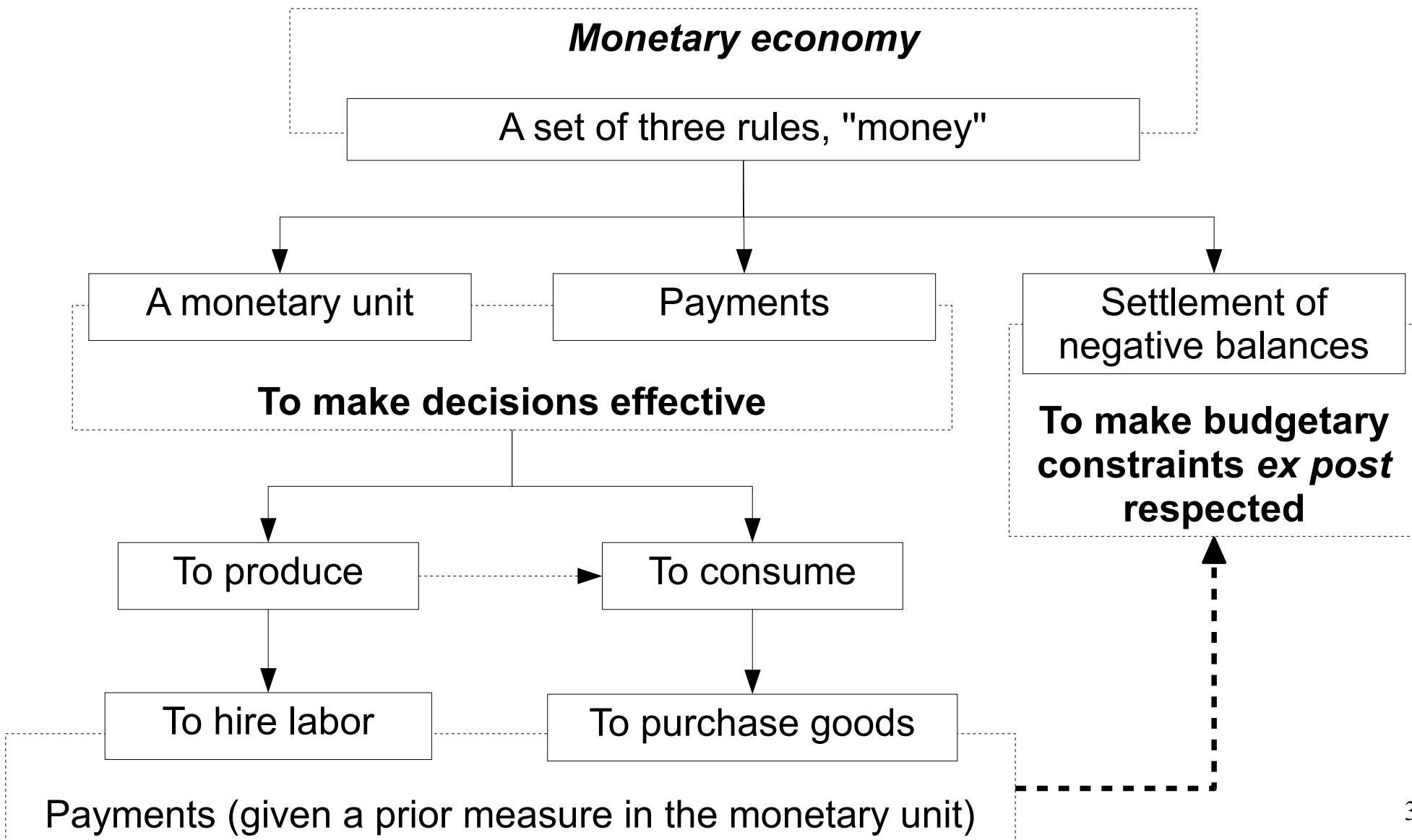

II. Disequilibrium dynamics and money

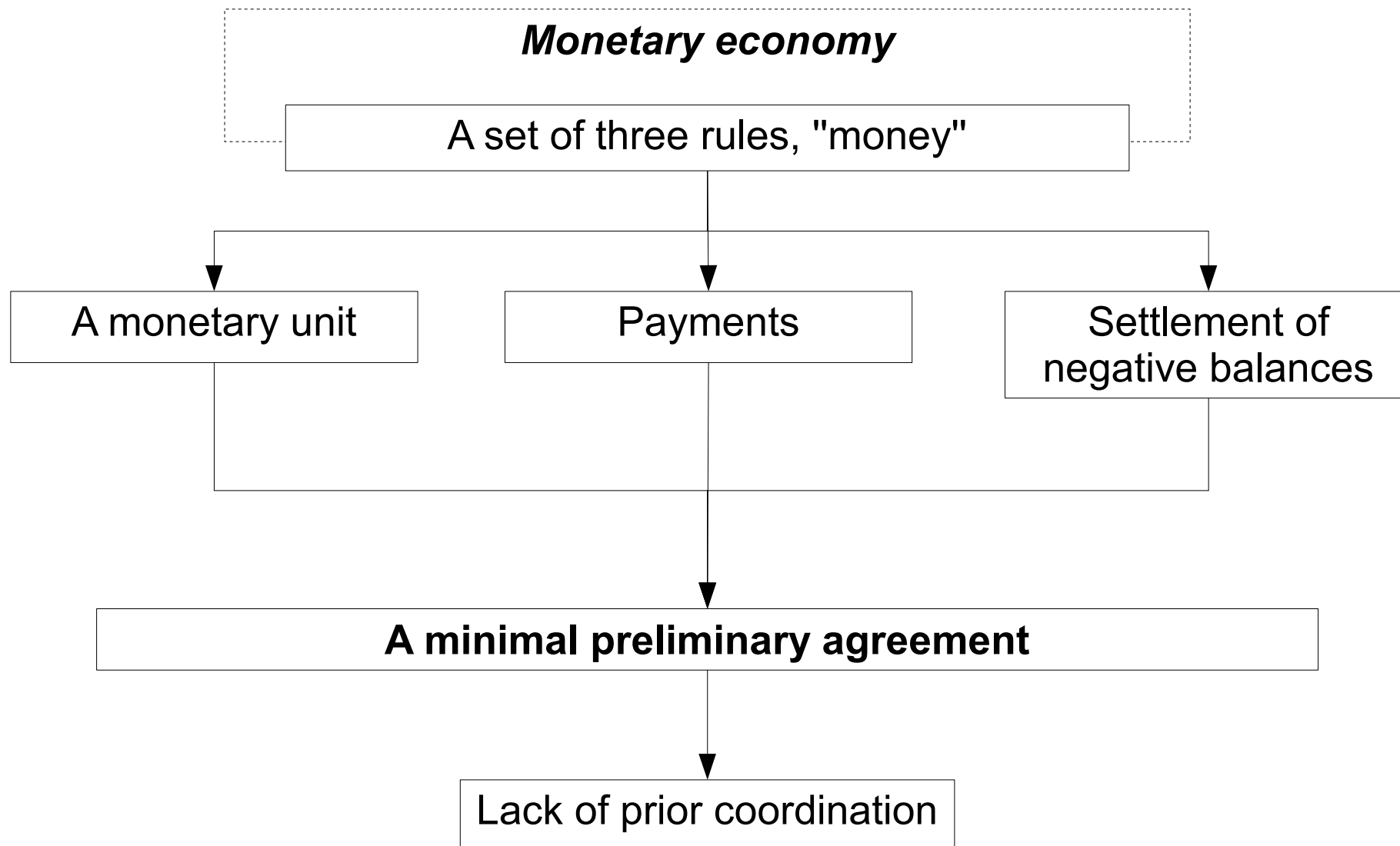

II. Disequilibrium dynamics and money

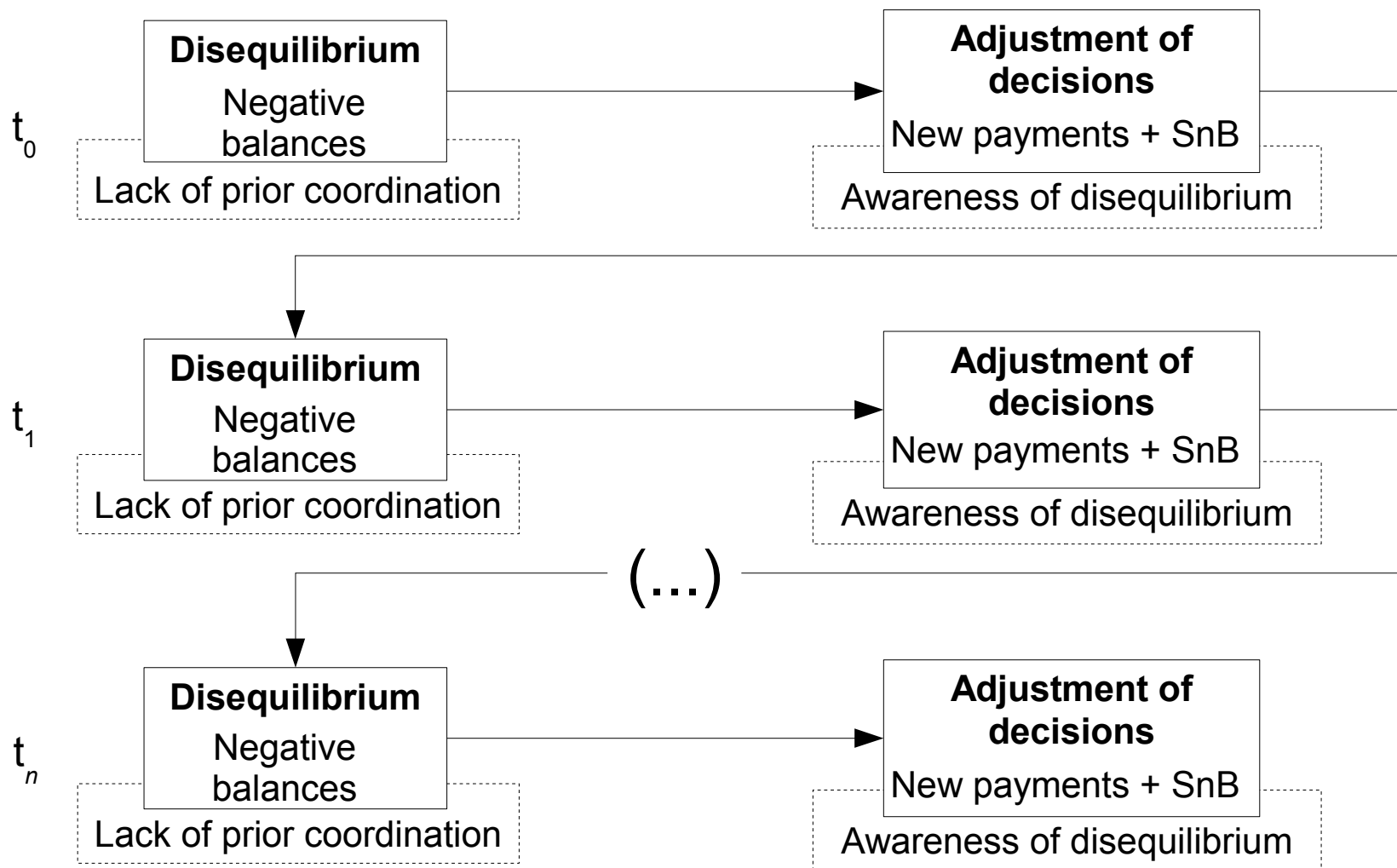

II. Disequilibrium dynamics and money

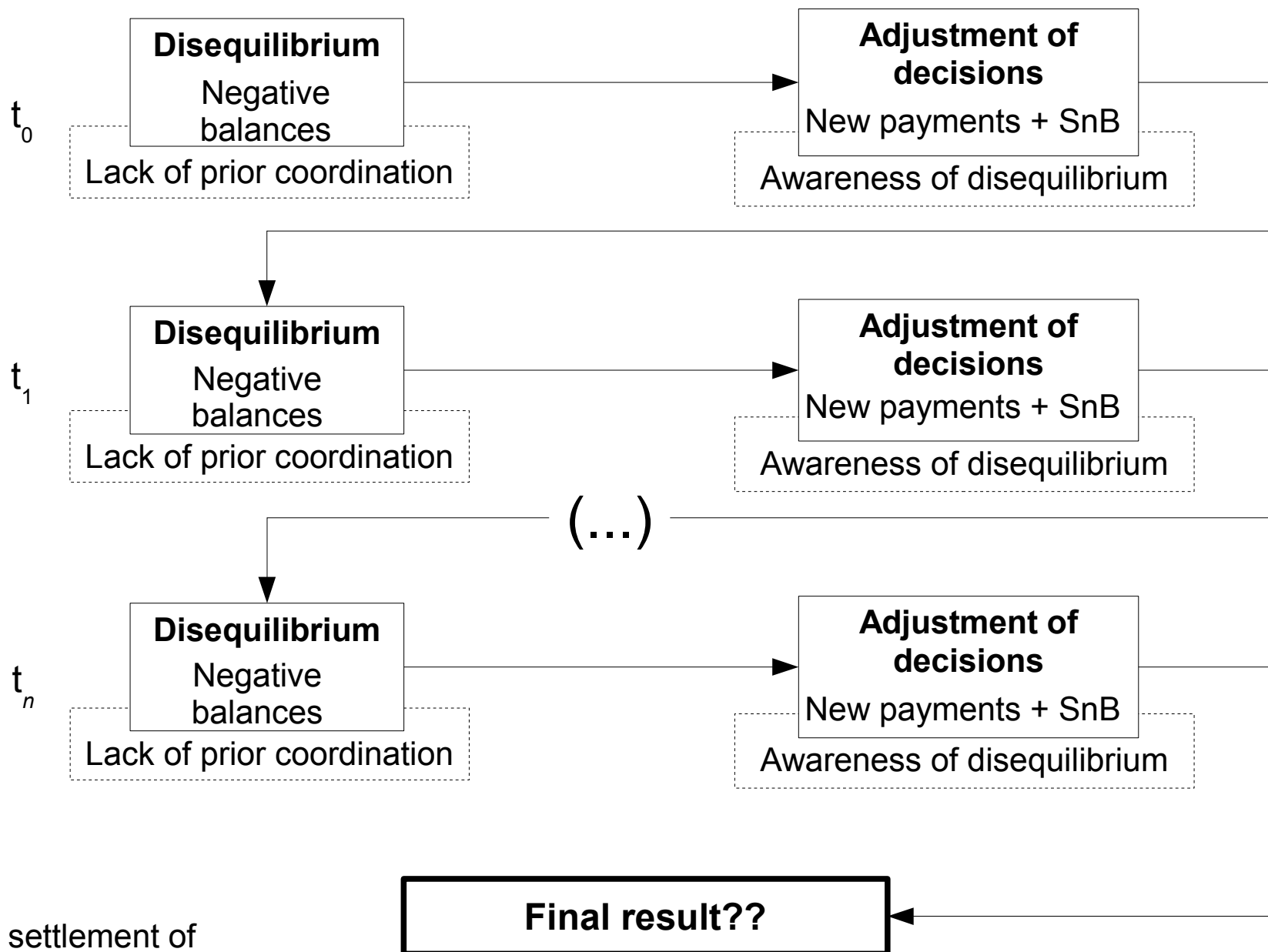

SnB = settlement of negative balance

THE END

Disequilibrium dynamics, the Edgeworth Process and the Hahn Process (Just a few words)

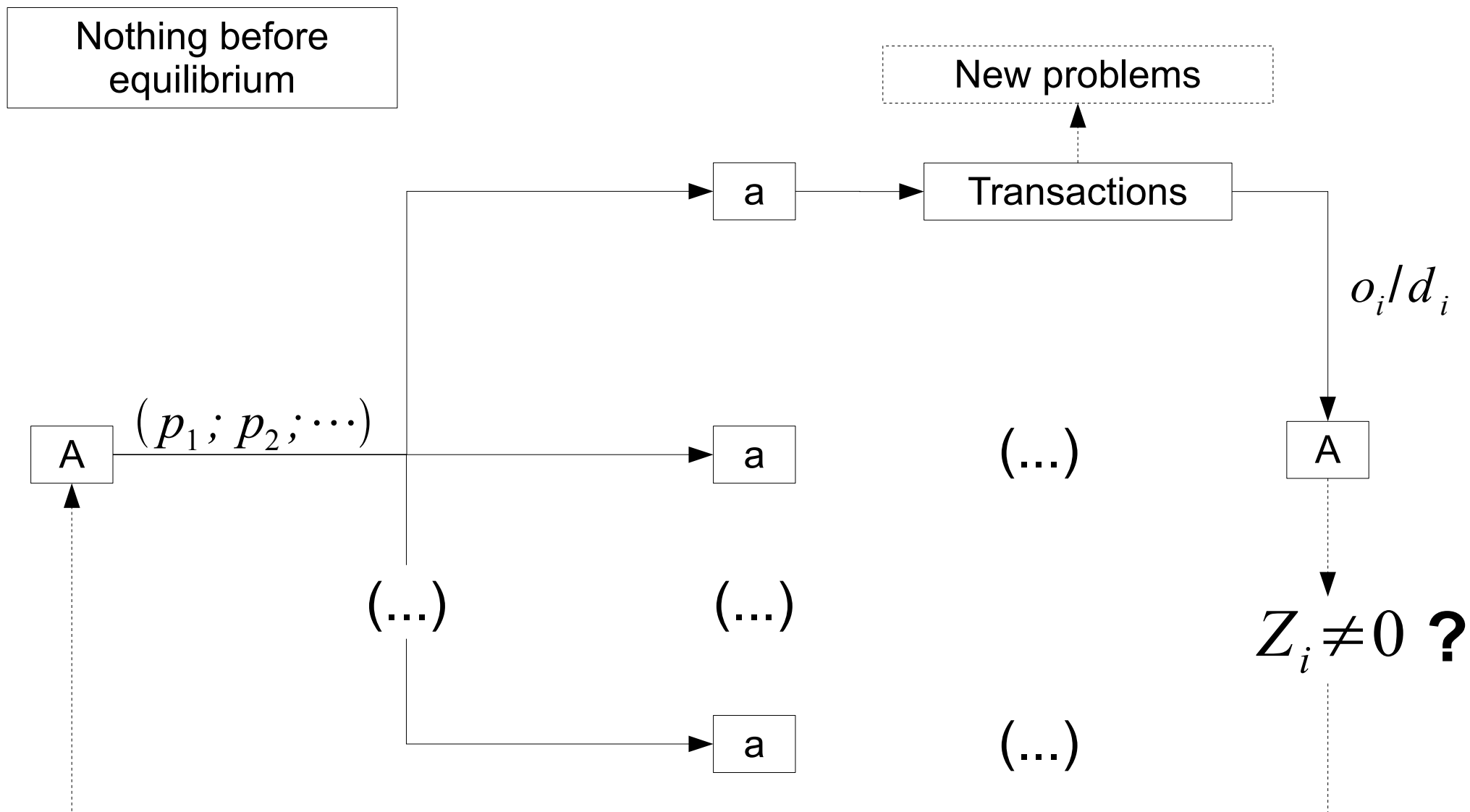

Disequilibrium dynamics and the "true model" à la Fisher (Just a few words)

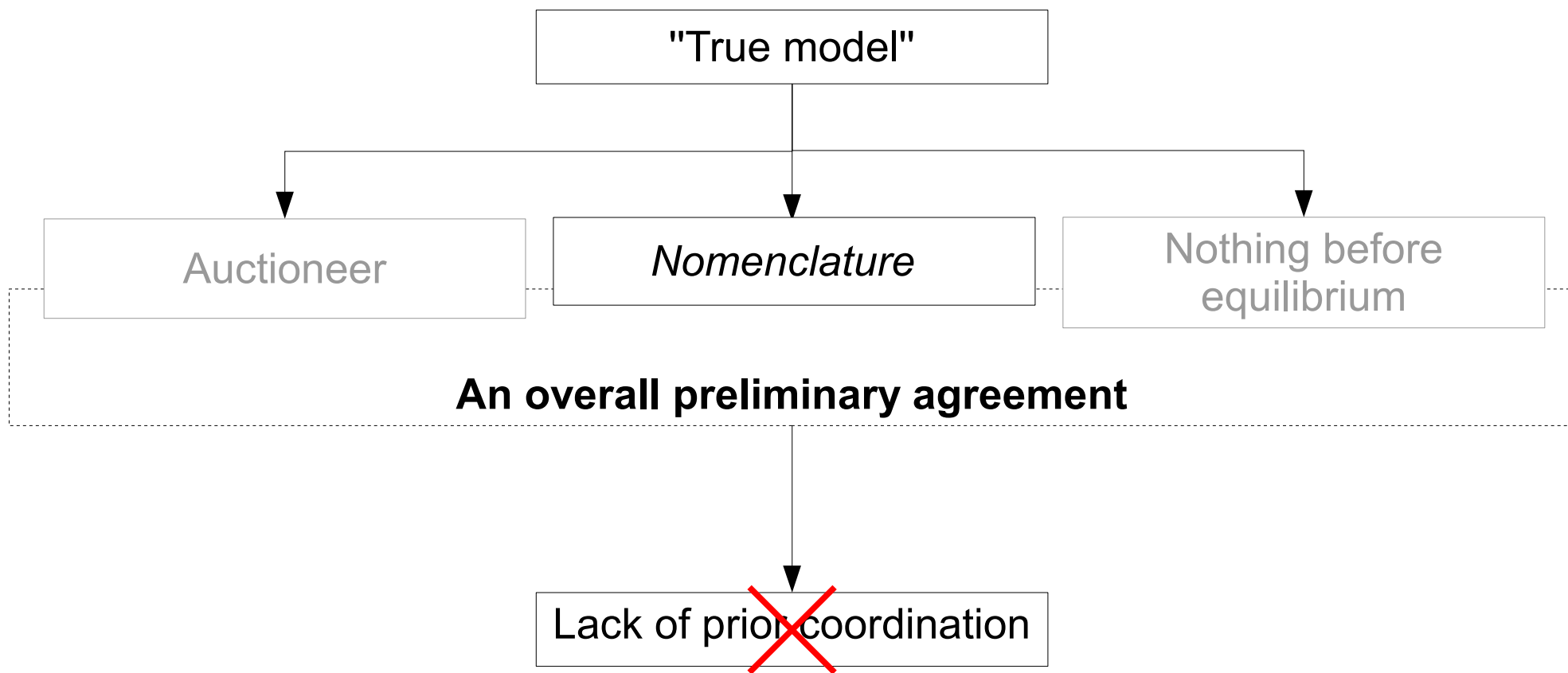

The Sonnenschein-Mantel-Debreu Theorem (Just a few words)

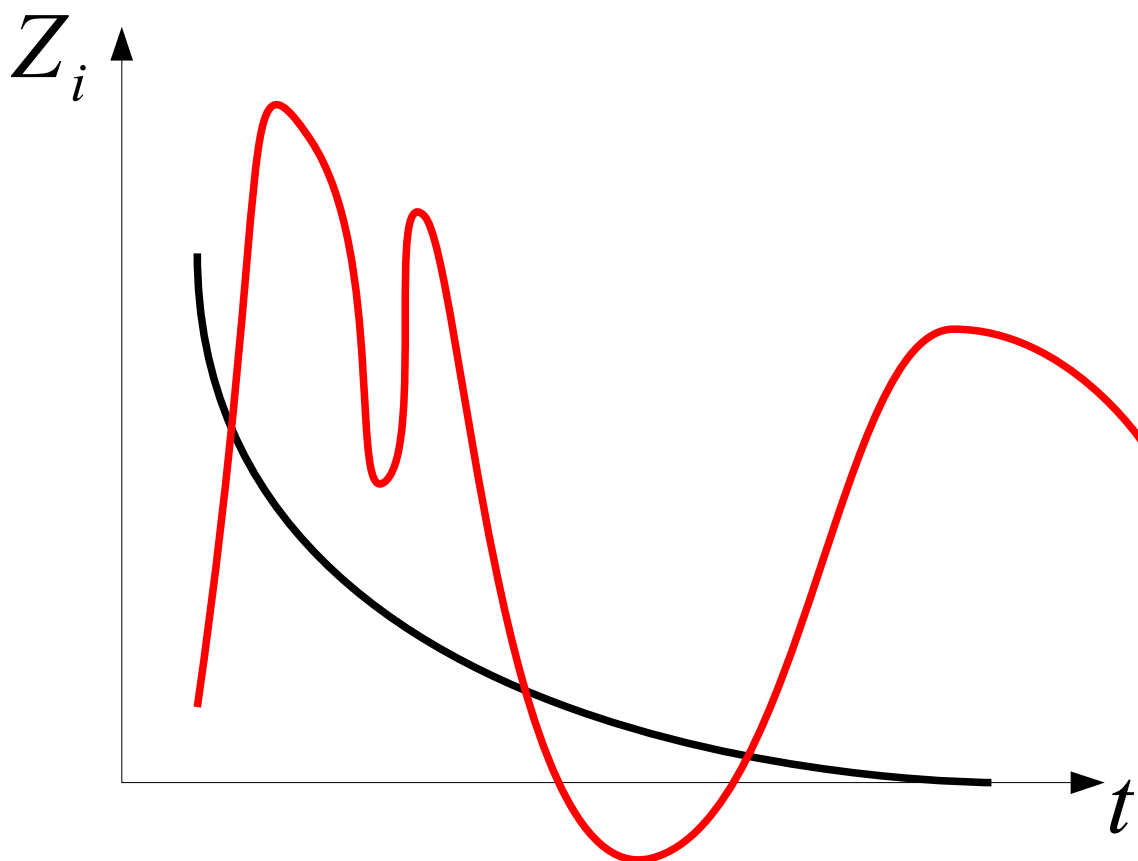

$$\frac{\partial p}{\partial t} = H_i[Z_i]$$

$$p = (p_1; p_2; \dots; p_n)$$

H_i Sign preserving

("Continuous" case)